





Classic Organ
538/i548
insignia™

Owner's Manual

 <div style="display: inline-block; border: 1px solid black; padding: 2px; text-align: center;"> CAUTION RISK OF ELECTRIC SHOCK DO NOT OPEN </div> 
ATTENTION: RISQUE DE CHOC ELECTRIQUE NE PAS OUVRIR
CAUTION: TO REDUCE THE RISK OF ELECTRIC SHOCK, DO NOT REMOVE COVER (OR BACK). NO USER-SERVICEABLE PARTS INSIDE. REFER SERVICING TO QUALIFIED SERVICE PERSONNEL.



The lightning flash with arrowhead symbol, within an equilateral triangle, is intended to alert the user to the presence of uninsulated "dangerous voltage" within the product's enclosure that may be of sufficient magnitude to constitute a risk of electric shock to persons.



The exclamation point within an equilateral triangle is intended to alert the user to the presence of important operating and maintenance (servicing) instructions in the literature accompanying the product.

INSTRUCTIONS PERTAINING TO A RISK OF FIRE, ELECTRIC SHOCK, OR INJURY TO PERSONS.

IMPORTANT SAFETY INSTRUCTIONS

SAVE THESE INSTRUCTIONS

WARNING – When using electric products, basic precautions should always be followed, including the following:

- | | |
|---|--|
| <ol style="list-style-type: none"> 1. Read these instructions. 2. Keep these instructions. 3. Heed all warnings. 4. Follow all instructions. 5. Do not use this apparatus near water. 6. Clean only with a dry cloth. 7. Do not block any of the ventilation openings. Install in accordance with the manufacturers instructions. 8. Do not install near any heat sources such as radiators, heat registers, stoves, or other apparatus (including amplifiers) that produce heat. 9. Do not defeat the safety purpose of the polarized or grounding-type plug. A polarized plug has two blades with one wider than the other. A grounding type plug has two blades and a third grounding prong. The wide blade or the third prong are provided for your safety. When the provided plug does not fit into your outlet, consult an electrician for replacement of the obsolete outlet. | <ol style="list-style-type: none"> 10. Protect the power cord from being walked on or pinched particularly at plugs, convenience receptacles, and the point where they exit from the apparatus. 11. Only use attachments/accessories specified by the manufacturer. 12. Never use with a cart, stand, tripod, bracket, or table except as specified by the manufacturer, or sold with the apparatus. When a cart is used, use caution when moving the cart/apparatus combination to avoid injury from tip-over. 13. Unplug this apparatus during lightning storms or when unused for long periods of time. 14. Refer all servicing to qualified service personnel. Servicing is required when the apparatus has been damaged in any way, such as power-supply cord or plug is damaged, liquid has been spilled or objects have fallen into the apparatus, the apparatus has been exposed to rain or moisture, does not operate normally, or has been dropped. |
|---|--|



For the U.K.

IMPORTANT: THE WIRES IN THIS MAINS LEAD ARE COLOURED IN ACCORDANCE WITH THE FOLLOWING CODE.

BLUE: NEUTRAL
 BROWN: LIVE

As the colours of the wires in the mains lead of this apparatus may not correspond with the coloured markings identifying the terminals in your plug, proceed as follows:
 The wire which is coloured BLUE must be connected to the terminal which is marked with the letter N or coloured BLACK.
 The wire which is coloured BROWN must be connected to the terminal which is marked with the letter L or coloured RED.
 Under no circumstances must either of the above wires be connected to the earth terminal of a three pin plug.

Notice to users

Information in this document is subject to change without notice. No part of this manual may be translated into any language, stored in a retrieval system, reproduced or transmitted in any form or by any means, electronic or mechanical, including photocopying and recording, for any purpose without the express written permission of **Rodgers Instruments LLC**.

RODGERS INSTRUMENTS LLC

1300 N.E. 25th Avenue
Hillsboro, Oregon 97124
USA
(503) 648-4181
www.rodgersinstruments.com

RODGERS IN CANADA

5480 Parkwood Way
Richmond, B.C. V6V 2M4
(604) 270-6332

© Copyright 2007. Rodgers Instruments LLC, a member of the Roland Group. All rights reserved.
Rodgers®, Rodgers Classic Organs®, Dimensional Sound Modeling®, Voice Palette™, DVM™, PDI™ and Chimes Sampling™ are trademarks or registered trademarks of Rodgers Instruments LLC, Hillsboro, Oregon. RSS® is a registered trademark of the Roland Corporation.

USING THE UNIT SAFELY

INSTRUCTIONS FOR THE PREVENTION OF FIRE, ELECTRIC SHOCK, OR INJURY TO PERSONS

About ⚠ WARNING and ⚠ CAUTION Notices

⚠ WARNING	Used for instructions intended to alert the user to the risk of death or severe injury should the unit be used improperly.
⚠ CAUTION	Used for instructions intended to alert the user to the risk of injury or material damage should the unit be used improperly. * Material damage refers to damage or other adverse effects caused with respect to the home and all its furnishings, as well to domestic animals or pets.

About the Symbols

	The ⚠ symbol alerts the user to important instructions or warnings. The specific meaning of the symbol is determined by the design contained within the triangle. In the case of the symbol at left, it is used for general cautions, warnings, or alerts to danger.
	The ⚡ symbol alerts the user to items that must never be carried out (are forbidden). The specific thing that must not be done is indicated by the design contained within the circle. In the case of the symbol at left, it means that the unit must never be disassembled.
	The ⏻ symbol alerts the user to things that must be carried out. The specific thing that must be done is indicated by the design contained within the circle. In the case of the symbol at left, it means that the power-cord plug must be unplugged from the outlet.

ALWAYS OBSERVE THE FOLLOWING

⚠ WARNING

- Before using this unit, make sure to read the instructions below and the Owner's Manual.

- Do not open or perform any internal modifications on the unit.

- Do not attempt to repair the unit or replace parts within it (except when this manual provides specific instructions directing you to do so). Refer all servicing to your retailer, the nearest Rodgers Service Center or an authorized Roland distributor, as listed on the "Information" page.

- Never use or store the unit in places that are:
 - Subject to temperature extremes (e.g., direct sunlight in an enclosed vehicle, near a heating duct, on top of heat-generating equipment); or are
 - Damp (e.g., baths, washrooms, on wet floors); or are
 - Humid; or are
 - Exposed to rain; or are
 - Dusty; or are
 - Subject to high levels of vibration.

- Make sure you always have the unit placed so it is level and sure to remain stable. Never place it on stands that could wobble or on inclined surfaces.

- The unit should be connected to a power supply only of the type described in the operating instructions or as marked on the unit.

- Do not excessively twist or bend the power cord, nor place heavy objects on it. Doing so can damage the cord, producing severed elements and short circuits. Damaged cords are fire and shock hazards!

⚠ WARNING

- This unit, either alone or in combination with an amplifier and headphones or speakers, may be capable of producing sound levels that could cause permanent hearing loss. Do not operate for a long period of time at a high volume level or at a level that is uncomfortable. If you experience any hearing loss or ringing in the ears, you should immediately stop using the unit and consult an audiologist.

- Do not allow any objects (e.g., flammable material, coins, pins); or liquids of any kind (water, soft drinks, etc.) to penetrate the unit.

- In households with small children, an adult should provide supervision until the child is capable of following all the rules essential for the safe operation of the unit.

- Protect the unit from strong impact. (Do not drop it!)

- Do not share an outlet with an unreasonable number of other devices. Do not connect excessive numbers of electrical devices to a single power outlet. In particular, when using a power strip, exceeding the rated capacity (watts/amps) of the power strip may cause heat to be generated, possibly melting the cable.

- Before using the unit in a foreign country, consult with your retailer, the nearest Service Center or an authorized distributor.

⚠ CAUTION

- The unit should be located so that its location or position does not interfere with its proper ventilation. 

- Always grasp only the plug on the power-supply cord when plugging into or unplugging from, an outlet or this unit. 

- Periodically wipe the dust off the power cord plug. From time to time, you should unplug the power cord from the AC outlet and use a dry cloth to wipe the dust off of it. You should also unplug the power cord from the AC outlet if you will not be using the device for an extended period of time. Dust or dirt that accumulates between the power cord plug and the AC outlet can cause a short circuit, possibly resulting in fire. 

- Manage cables for safety. Ensure that the connected cables are organized and managed in a safe manner. In particular, place the cables out of reach of children. 

- Never climb on top of, nor place heavy objects on the unit. 

- Never handle the power cord or its plugs with wet hands when plugging into or unplugging from, an outlet or this unit. 

- If you need to move the instrument, take note of the precautions listed below. At least two persons are required to safely lift and move the unit. It should be handled carefully, all the while keeping it level. Make sure to have a firm grip, to protect yourself from injury and the instrument from damage. 
 - Check to make sure the screw securing the unit to the stand have not become loose. Fasten them again securely whenever you notice any loosening.
 - Disconnect the power cord.
 - Disconnect all cords coming from external devices.

- Before cleaning the unit, turn off the power and unplug the power cord from the outlet. 

- Whenever you suspect the possibility of lightning in your area, pull the plug on the power cord out of the outlet. 

- When closing the sliding rolltop, be careful not to pinch your fingers. 

- When using the bench, please observe the following points: 
 - Do not use the bench as a toy or as a stepping stool.
 - Do not allow two or more persons to sit on the bench.
 - Do not sit on the bench if the bolts holding the bench legs are loose. (If the bolts are loose, immediately re-tighten them using the supplied wrench.)

- Do not walk on the pedal board to avoid applying too much weight to the pedals. The pedals are only meant for playing music, not as a toy. 

- Be careful when opening/closing the roll top to avoid getting your fingers pinched. Adult supervision is required whenever small children want to use the unit. 

⚠ CAUTION

- Should you remove screws and knob bolt, make sure to put them in a safe place out of children's reach, so there is no chance of them being swallowed accidentally. 

Important notes

In addition to the items listed under "Important safety instructions" on p. 2 and "Using the unit safely" on p. 4, please read and observe the following:

Power supply

- Do not use this unit on the same power circuit with any device that will generate line noise (such as an electric motor or variable lighting system).
- Before connecting this unit to other devices, turn off the power to all units. This will help prevent malfunctions and/or damage to speakers or other devices.
- When you turn off the power, the screen and indicators of this device will go dark, but this does not mean that the main power supply is completely disconnected. If you need to completely shut off the power supply, turn off the power switch of this device and then unplug it from the AC outlet. Connect this device to an AC outlet that is as close and accessible as possible.

Placement

- Electromagnetic radiations may cause a deterioration of audio performances. Such possible deterioration consists in an audio signal being emitted. On ceasing the electromagnetic noise, the emission of the audio signal will simultaneously stop.
- Using the unit near power amplifiers (or other equipment containing large power transformers) may induce hum. To alleviate the problem, change the orientation of this unit; or move it farther away from the source of interference.
- This device may interfere with radio and television reception. Do not use this device in the vicinity of such receivers.
- Noise may be produced if wireless communications devices, such as cell phones, are operated in the vicinity of this unit. Such noise could occur when receiving or initiating a call or while conversing. Should you experience such problems, you should relocate such wireless devices so they are at a greater distance from the 538/i548 or switch them off.
- Do not expose the unit to direct sunlight, place it near devices that radiate heat, leave it inside an enclosed vehicle or otherwise subject it to temperature extremes. Also, do not allow lighting devices that normally are used while their light source is very close to the unit (such as a piano light) or powerful spotlights to shine upon the same area of the unit for extended periods of time. Excessive heat can deform or discolor the unit.
- To avoid possible breakdown, do not use the unit in a wet area, such as an area exposed to rain or other moisture.
- Do not allow rubber, vinyl or similar materials to remain on the instrument for long periods of time. Such objects can discolor or otherwise harmfully affect the finish.
- Do not put anything that contains water (e.g., flower vases) on the cabinet. Also, avoid the use of insecticides, perfumes, alcohol, nail polish, spray cans, etc., near the unit. Swiftly wipe away any liquid that spills on the unit using a dry, soft cloth.
- Do not allow objects to remain on top of the keyboard or pedal board. This can be the cause of malfunction, such as keys ceasing to produce sound.
- Do not paste stickers, decals or the like to this instrument. Peeling such matter off the instrument may damage the exterior finish.

Maintenance

- To clean the unit, use a dry, soft cloth; or one that is slightly dampened. Try to wipe the entire surface using an equal amount of strength, moving the cloth along with the grain of the wood finish. Rubbing too hard in the same area can damage the finish.
- Never use benzene, thinners, alcohol or solvents of any kind, to avoid the possibility of discoloration and/or deformation.

Additional precautions

- Please be aware that the contents of memory can be irretrievably lost as a result of a malfunction or the improper operation of the unit. To protect yourself against the risk of losing important data, we recommend that you periodically save a backup copy of important data you have stored using a USB storage device or an external sequencer.
- Unfortunately, it may be impossible to restore the contents of data that was stored externally once it has been lost. Rodgers assumes no liability concerning such loss of data.
- Use a reasonable amount of care when using the unit's buttons, sliders or other controls; and when using its jacks and connectors. Rough handling can lead to malfunctions.
- Never strike or apply strong pressure to the display.
- When connecting/disconnecting all cables, grasp the connector itself—never pull on the cable. This way you will avoid causing shorts or damage to the cable's internal elements.
- A small amount of heat will radiate from the unit during normal operation.

Using headphones

- When headphones are connected, the speakers inside the console are muted. Be aware, however, that it is possible that external speakers connected to the console may not be muted. **Do not connect/disconnect headphones while playing.**
- To avoid disturbing your neighbors, try to keep the unit's volume at reasonable levels. You may prefer to use headphones, so you do not need to be concerned about those around you (especially when it is late at night).
- When you need to transport the unit, pack it in shock-absorbent material. Transporting the unit without doing so can cause it to become scratched or damaged and could lead to malfunction.
- Use a cable from Roland to make the connection. If using some other make of connection cable, please note the following precautions. Some connection cables contain resistors. Do not use cables that incorporate resistors for connecting to this unit. The use of such cables can cause the sound level to be extremely low or impossible to hear. For information on cable specifications, contact the manufacturer of the cable.

Contents

Using the unit safely	4	4. Other functions	28
1. Introduction	9	Console display and controls	28
How to use this manual	9	Accessing organ control functions	28
2. Quick tour	10	Setting the display's contrast and brightness	29
Console controls	10	Quick Menu parameters	30
Connecting the pedalboard cables (538 only)	11	Tuning	33
Using the music rest (538 only)	12	Tremulant controls	33
Folding down the music rest (538 only)	12	Adjusting tremulant settings	33
Locking the rolltop	12	Using orchestral sounds	34
Switching the 538/i548 on and off	12	Selecting orchestral voices	34
Manuals and pedalboard	12	Settings for the orchestral sounds	35
Setting the volume	13	Using the ROOM MODELING effect	36
Stereo headphone socket	13	Expression function	36
Demo songs	13	Temperaments	37
Activating stops	13	Selecting a temperament	38
Couplers	14	Random tuning	38
Intermanual couplers	14	Valve Release	39
MELODY coupler	14	Selecting the stop configuration	39
BASS coupler	14	Volume settings	40
Melody and Bass coupler ranges	15	Master Volume	40
General cancel ('0')	15	Changing the balance of the divisions	40
Performing with the metronome	15	Audio inputs and outputs	41
Storing registrations	16	Other AUDIO CONTROL parameters	41
About the memories	16	Saving general settings	42
Saving your settings	17	Formatting a USB storage device	42
Saving settings to a divisional memory	17	5. MIDI functions	44
Selecting a memory	17	MIDI couplers	44
Configuring the MANUAL I memories to include the PEDAL registration	18	Enabling MIDI	44
Expression/crescendo	19	MIDI settings	45
Tremulants	19	MIDI Channel	45
Tutti	20	Changing Manual I's MIDI channel	45
Transpose	20	Tone (Prg, Msb, Lsb)	45
About stop families	20	Saving a tone address in a registration memory	46
Pitch designations	21	Octave	47
Celeste ranks	21	Velocity	47
ORCH/MIDI couplers	22	Fixed Velocity (1~127)	47
Orchestral couplers (ORCH)	22	Keyboard velocity (Kbd)	48
MIDI couplers	22	Expression Velocity (EXP)	48
3. Using the 538/i548's recorder	23	Pan	48
Recording a song	23	Reverb	49
Saving your song	23	Chorus	49
Playing back songs	25	Local	49
Metronome and count-in	26	Footswitch and Expression parameters	50
Deleting songs	27	Foot Switch	50
		Expression	50
		Global MIDI settings	51
		All Notes Off	51
		Master channel	51
		Registrations (Stop Change)	51
		Seq. Update	52
		MIDI Device ID	53
		Saving MIDI settings	54

6. Data management functions.....	55
Using the 'Memory Set' function.....	55
Saving the general and divisional memories.....	55
Loading the general and divisional memories.....	55
Loading general or MIDI parameter sets.....	56
Restoring the factory-default memory settings ...	57
7. Care and maintenance.....	60
8. Miscellaneous.....	61
Pipe support.....	61
List of shortcuts.....	61
Rodgers MIDI System Exclusive	61
MIDI Implementation Chart	63

1. Introduction

Grand, glorious sound is the hallmark of the Rodgers 538/i548. Providing a rich and spacious ensemble sound complemented by crystal-clear definition, the 538/i548 will take you to new musical heights, while sustaining the tradition of quality, craftsmanship and innovation you've come to expect from Rodgers.

Dimensional Sound Modeling® is the 21st Century standard in digital organ-building technology. Dimensional Sound Modeling ushers in a new era of choice and control to create authentic pipe organ sound and room acoustics as never before possible. Dimensional Sound Modeling technology takes you from virtual to reality. With unmatched user control over every major facet of the organ, you can create a sound and an acoustical environment modeled to your taste and musical needs.

Each selection can be easily stored in the organ's memories, allowing you to authentically recreate virtually any musical style or individual performance desired with the push of a button.

With remarkable flexibility and superior sound the 538/i548 is a perfect choice for any home, concert or worship setting. Thanks to advanced modeling techniques, almost all sonic aspects can be set to your liking.

This manual will help with the exploration of the expansive capabilities and the variety of features and functions offered by this instrument. As highly sophisticated as the 538/i548 is, the features are easy to use and to access, creating a most satisfying musical experience for the player and listener.

To keep abreast of the latest news and other items of interest, visit the Rodgers website at:
www.rodgersinstruments.com.

How to use this manual

This manual is divided into four main sections:

- | | |
|------------------------|---|
| Quick tour | An introduction to the 538/i548. Use this section to familiarize yourself with the instrument (page 10). |
| Other functions | A more detailed description of controls and features. Use this section to find additional information about the capabilities and operation of the 538/i548 (page 28). |
| MIDI functions | A description of organ features and settings for use with an external MIDI (Musical Instrument Digital Interface) device (page 44). |
| Specifications | See p. 64. |

2. Quick tour

This section provides an overview of the basic operations of the 538/i548.

Console controls

The console controls for models 538/i548 are illustrated below.

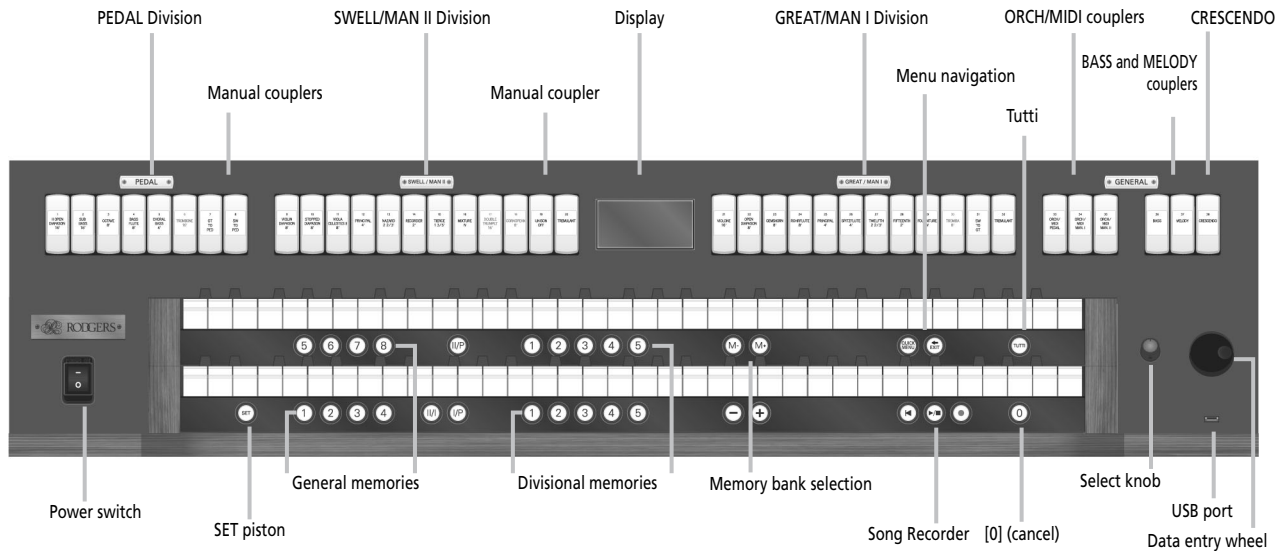

Most speaking stops have different names, and the SWELL (MAN II) and GREAT (MAN I) divisions are shifted (GREAT to the right of the display, SWELL to the left).

Note: All "Quick Menu" parameters refer to the divisions as "Pedal", "Manual I", and "Manual II". "Manual I" represents the "GREAT" manual, "Manual II" refers to the "SWELL" manual.

Connecting the pedalboard cables (538 only)

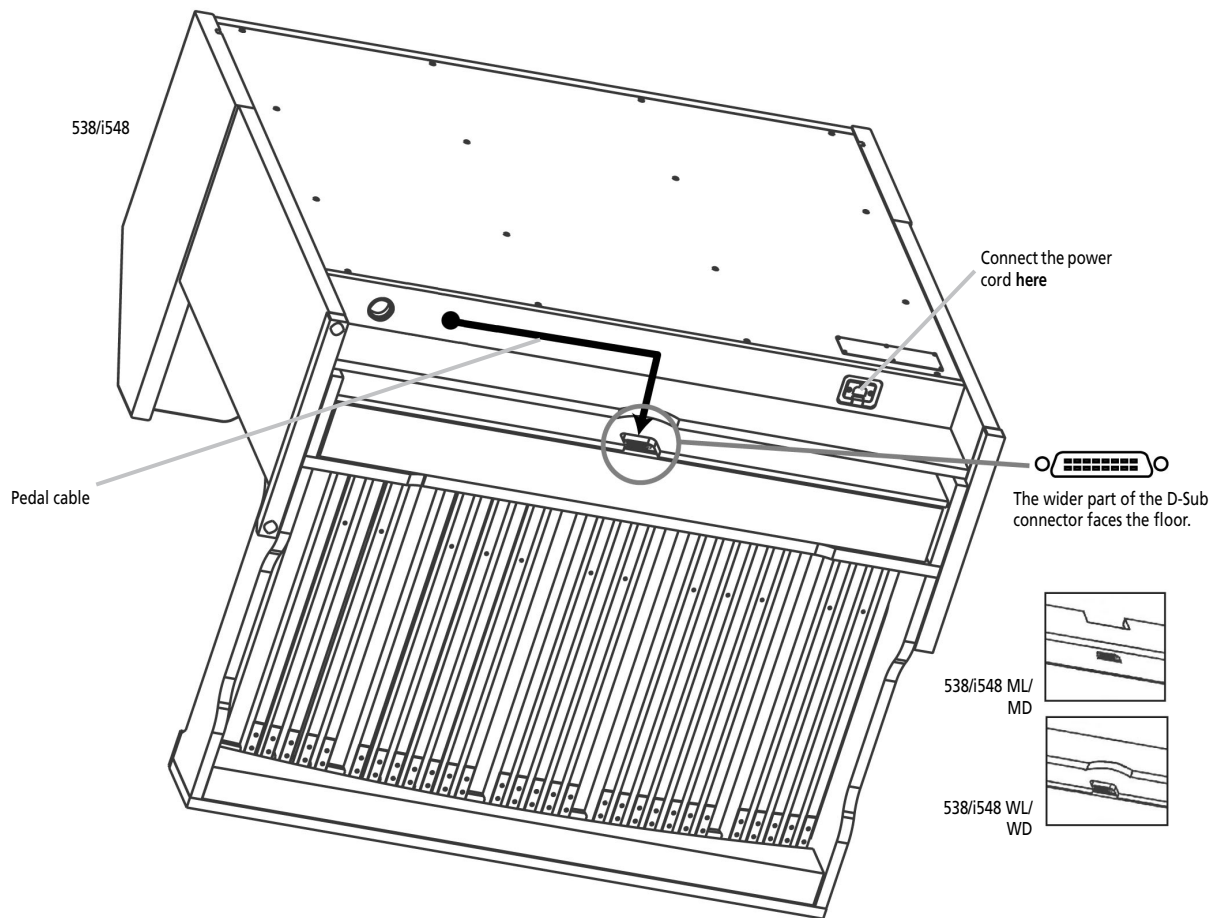

- (1) Set up the organ in such a way that one person can kneel behind it and position the pedalboard at about 1m from the organ.
- (2) Connect the power cord to the instrument (left side below the console) and to a suitable wall outlet.
- (3) Slide the connection cable through the hole in the organ's center (see the arrow above) and pull it out from the organ's front.
- (4) Connect the D-Sub plug to the pedalboard, taking care to it the right way (see above).
- (5) Ask one person to stand behind the 538/i548 and to gently pull the D-Sub cable towards the rear while you push the pedalboard towards the 538/i548.
- (6) Arrange the slack end of the D-Sub cable in such a way that it cannot be damaged when the pedalboard or the 538/i548 is moved.
- (7) Push the 538/i548 against the wall or desired surface, then move the pedalboard accordingly.

Using the music rest (538 only)

- (1) Grasping the music rest with both hands, pull it toward you until it is in the upright position.
- (2) While holding the music rest with one hand, fold out the two supporting legs at the back.
- (3) Gently push the music rest towards the back of the instrument, making sure that it is held in place by the supporting legs.

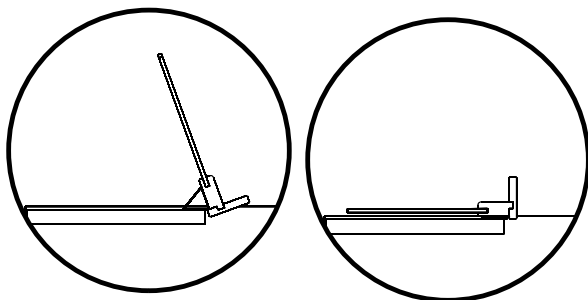

Folding down the music rest (538 only)

- (1) Grasping the music rest with both hands, pull it toward you until it is in the upright position.
- (2) While holding the music rest with one hand, push the two supporting legs towards the music rest.
- (3) Gently fold down the music rest. Don't apply excessive force.

Locking the rolltop

Use the supplied key to lock (and unlock) the 538/i548's rolltop if necessary.

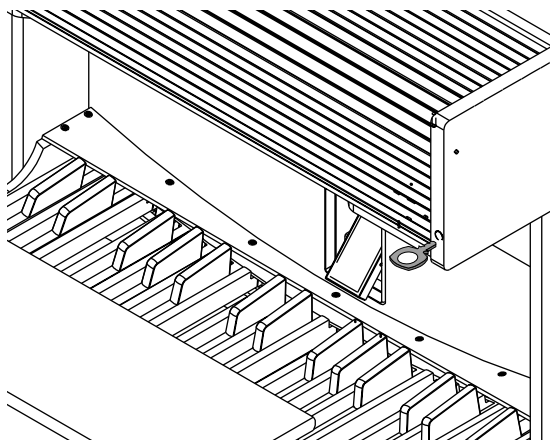

To switch the organ off:

- (3) Press the lower part of the **POWER ON** switch.

Manuels and pedalboard

The 538/i548 has two keyboards played by the hands, commonly referred to as **manuels**. In order from bottom to top, they are **Manual I** and **Manual II**.

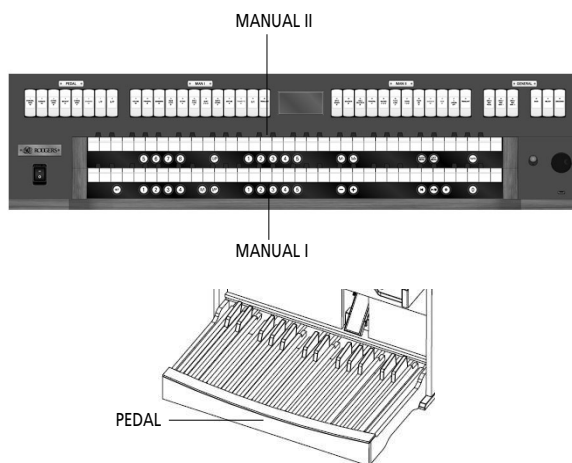

Switching the 538/i548 on and off

To switch the organ on:

- (1) Open the rolltop by sliding it towards the rear of the 538/i548.
- (2) Press the top part of the **POWER ON** switch (to the left of the lower manual).
The organ performs a self-diagnostic test of its systems over the next few seconds. When completed, the display looks as follows, indicating that the 538/i548 is ready to play.



Each manual can play a group of stops, known as a **division**. Stops played by manual I make up the **MAN I** division and stops played by manual II are referred to as the **MAN II** division.

The keyboard played by the feet is referred to as the **pedalboard**, and stops, which are played by the pedalboard, make up the **PEDAL** division.

Setting the volume

Special situations and individual preferences sometimes require a temporary change in the overall volume of the organ. This may be due to a large attendance and the need for additional sound to fill the room; at other times, it may be desirable to reduce the overall level of the organ to accommodate a smaller audience.

- (1) The **GENERAL VOLUME** knob on the connector panel (right, below the keydesk) can be used to set the 538/i548's overall volume. Adjust the **GENERAL VOLUME** knob located on the black input/output box underneath the keydesk to the right.

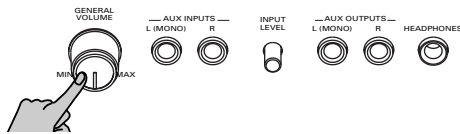

You can use the "Quick Menu" preset a general volume setting (page 40) and to set the volume of each division individually (page 40).

Stereo headphone socket

The console is equipped with a 1/4" stereo HEADPHONES socket located on the connector panel to the right underneath the keydesk. Plugging a set of headphones into this jack disables the sound from all speakers.

Demo songs

The 538/i548 is equipped with a demo song function that plays MIDI sequences stored inside the instrument. This feature allows you to demonstrate the 538/i548 or to hear how the instrument sounds from another location in the room (by starting a demo song and then walking around).

There are several demo songs stored inside your instrument. These songs cannot be changed.

- (1) Press the **QUICK MENU** piston.

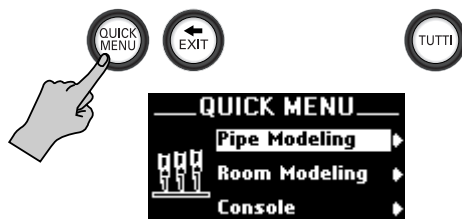

- (2) Use the Select knob to select the "Demo Songs" entry:

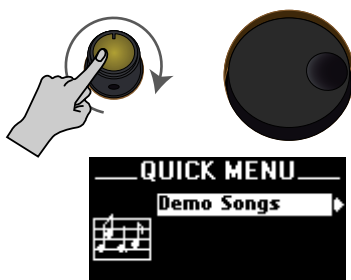

- (3) Press the **QUICK MENU** button. The display now looks as follows:



- (4) Use the Select knob to select the demo song you want to listen to. (See your instrument's display for the titles of the available demo songs.)
- (5) Press **▶/■** to start playback of the selected song(s).

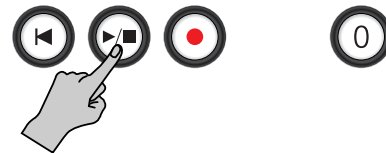

At the end of the selected demo song, the 538/i548 starts playing back the following song.

- (6) Press **▶/■** again to stop playback.
- (7) Press and hold **◀/■** to return to the main page.



Activating stops

The term **stop** is used to describe a single voice on an organ. The 538/i548 has a large array of stops, each of which is given a name, such as **Violone 16'**, **Spitzflöte 4'**, **Mixture IV**, etc. A stop will sound if it is activated and keys or pedals that control it are pressed. For example, the **Principal 16'** stop in the Pedal division will sound if it is activated and notes are played on the pedalboard.

To activate a stop:

- Press the bottom half of the tilt tab until it lights and release it.

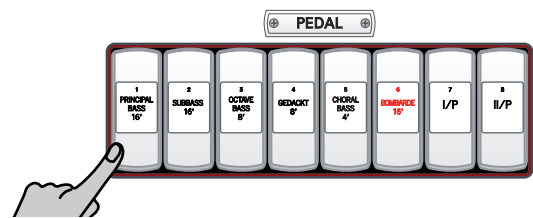

To silence a stop:

- Press the top half of the tilt tab until it goes dark and release.

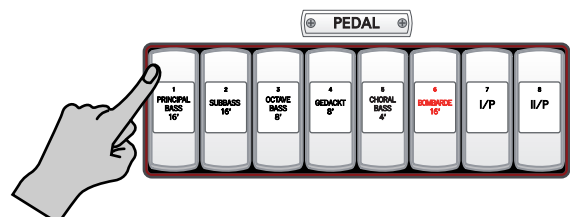

Couplers

A coupler is a switch (a tilt tab), which activates a link between a control device (usually a division keyboard) and another feature of the organ. The most commonly used couplers are the intermanual couplers. Other couplers, such as the ORCH/MIDI coupler, allow a division keyboard (PEDAL, MAN I, MAN II) to play sounds from the ORCH memory bank or an external MIDI source.

Intermanual couplers

The following couplers are referred to as **intermanual couplers**, because they connect a division associated with one manual to an additional manual, or to the pedalboard. They are activated by tilt tabs located above manual II or dedicated pistons, and allow you to control multiple divisions from one manual.

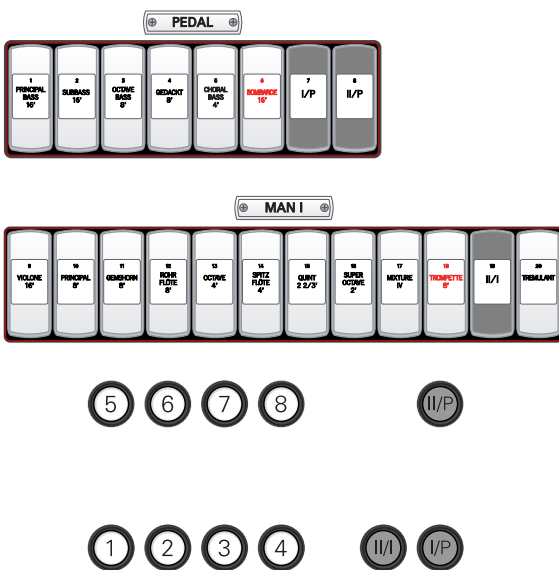

The first name listed in the coupler is the division that is being "coupled"; the second name denotes the division to which the division is coupled. "II/I" literally means, "Connect the MANUAL II division to MANUAL I".

Couplers allow you to control a larger portion of the organ from one manual or the pedalboard and are useful in achieving larger or more varied registrations. For example, by activating the **II/I** coupler, the musician could play stops in the MAN II division from manual I.

To activate a coupler:

- (1) Press the bottom half of the tilt tab until it lights and release.

To disengage a coupler:

- (2) Press the top half of the tilt tab. It will go dark.

MELODY coupler

One of the most popular organ registrations utilizes a melody voice on one manual and accompaniment on another manual. Sometimes, however, it is difficult to separate the hands on two manuals. For this reason, the Rodgers **MELODY** coupler was devised.

When the melody coupler is activated, the highest note played on manual I uses a registration from manual II. This allows you to use both an accompaniment and solo registration, even though you're playing on one manual.

The melody coupler is located on a tab labeled **MELODY** and lights when it is engaged. It is also available for orchestral sounds.

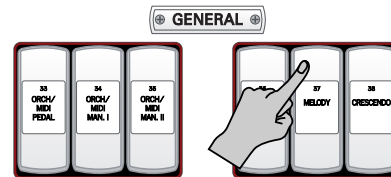

When **MELODY** is engaged, any selected stop or orchestral voice in the MAN II division sounds from the highest key being played on manual I.

The melody coupler is used when the corresponding intermanual coupler is not engaged. For example, when **MELODY** is engaged, the **II/I** coupler should not be used to achieve the proper melody effect.

The **MELODY** coupler operates when the top note (the melody note) is between keys 25 and 61 on manual I (see the illustration at the bottom of this page). The split point can be changed.

Note: The **MELODY** coupler's status can only be saved to a general memory.

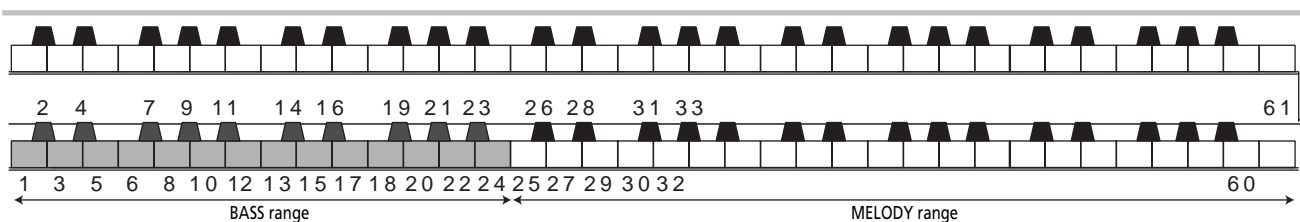

BASS coupler

The **BASS** coupler is much like the **MELODY** coupler, except that it adds the PEDAL registration to the lowest note played on manual I. This allows you to easily add a bass part to anything played on manual I.

The **BASS** coupler lights when engaged. Any selected registration in the PEDAL division will sound from the lowest key being played on manual I. This provides a pedal bass sound without actually playing the pedalboard.

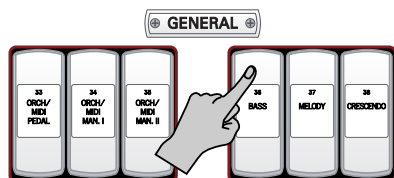

The **BASS** coupler affects keys 1~25 of manual I, but this can be changed (see below). It is also available for the orchestral sounds. See the illustration on page 14.

Note: The **BASS** coupler's status can only be saved to a general memory.

Melody and Bass coupler ranges

The **MELODY** and **BASS** coupler ranges depend on the split point. The split point for the bass range can be set to any key between notes "1" and "25" (the default key is "25"). The split point for the MELODY range can be changed between notes "25" and "61".

The **MELODY** range is on the **right** side of the split point, and the **BASS** range is on the **left** side. The split point is the lowest note of the **MELODY** range.

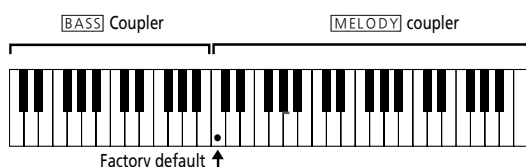

- (1) Hold **SET** while pressing the **BASS** or **MELODY** coupler (it flashes).

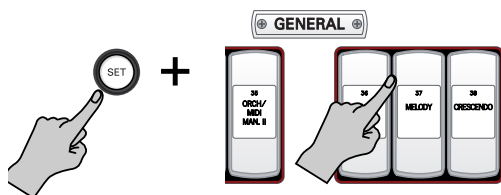

- (2) Press the desired key (1~25) on manual I (the lower manual) or manual II (upper manual).

Note: This setting cannot be saved and needs to be made each time you need it after switching on the organ.

General cancel ('0')

Activated stops and couplers can be cleared quickly by pressing the **0** piston. Simply press and release it to cancel a registration.



Pressing **0** + **SET** returns selections to the general parameter settings. In addition, **0** + **SET** changes the temperament back to EQUAL and sets the MIDI coupler parameters to their power-up default.

Performing with the metronome

You can perform while the metronome sounds. The 538/i548 provides a versatile metronome function. You can adjust the volume or time signature of the metronome, and specify when the metronome should sound.

- (1) Press the **QUICK MENU** piston.

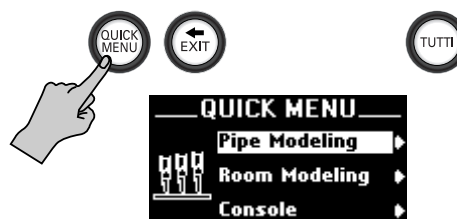

- (2) Use the Select knob to select the "Song Recorder" entry:



- (3) Press the **QUICK MENU** piston to confirm your choice.

Note: If you select the wrong entry, you can return to the previous level by briefly pressing the **EXIT** piston.

- (4) Use the Select knob to select "Metronome".

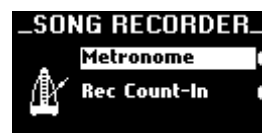

- (5) Press the **QUICK MENU** piston.



You can also select this page directly by holding down **SET** while pressing **▶/■**.

(6) Use the Select knob to select the desired parameter and change its setting with the data entry wheel:

- Setting Allows you to switch the metronome on and off. The third option, "Rec", means that the metronome is only audible while you are recording (see p. 23).
- ♪ Allows you to set the tempo (20~250).
- Vol Allows you to set the metronome's volume (this setting is also used by the Count-In function).
- TSig Allows you to set the time signature. This value is only used while you are not playing back a recorded song (i.e. when practising a new piece). The setting range is 2/2, 1/4~7/8, 3/8, 6/8, 9/8 or 12/8.

(7) Press and hold the  piston to return to the main page.



Storing registrations

By now, you may have experimented with combinations of stops and couplers and have started to get a feel for the tremendous versatility of the 538/i548. In organ terms, these combinations of stops and couplers are referred to as **registrations**.

Obviously, once you've found a desirable registration, you'll want to be able to recall it quickly and easily. With Rodgers' powerful digital technology, you can store and recall stops, pistons and even MIDI settings.





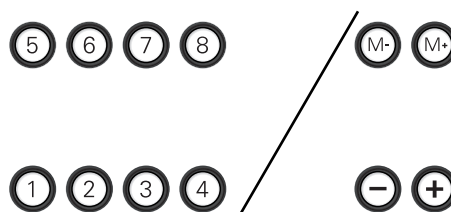

Note: The Rodgers MIDI system is covered in great detail, starting on page 44.

About the memories

There are two kinds of memories on the 538/i548:

- **General memories** that apply to all sections and divisions. There are 32 such memories, divided over 4 banks of 8 memories.



Banks are selected using the / pistons. The memories can be selected using the ~ and/or the / pistons.

- **Divisional memories** that only apply to the manual (i.e. division) under which they are located.



There are five such memories per division. The memories of manual I can be set to include the registration of the PEDAL division. See page 18 for how to set this function.

Pressing a piston with your thumb will cause the stored registration to be recalled instantly.

Note: Your Rodgers organ has factory-set registrations for many pistons—try them!

Each of the available memories can be easily changed to suit your particular needs and tastes.

As stated above, general memories affect the entire organ, while divisional memories affect a single division. For example, you could use one *general* memory to recall stops, couplers and MIDI settings on every division at once, or you could use a MAN II *divisional* memory to change only the registration of manual II.

Saving your settings

The 538/i548 is equipped with factory registrations, each of which can be used for a wide variety of wonderful musical effects. However, the contents of any memory can be easily changed to suit your particular needs.

Saving all settings to a general memory

- (1) Select the desired stops, couplers and MIDI settings. See page 13 for details.
If the memory area is protected ("Locked"), the following message is displayed when you execute steps (2) and (3) below:



In that case, proceed as follows:

- Press and hold [M+] for a few seconds.



- Use the data entry wheel to select "Unlocked".
While "Locked" is selected, you can neither save your settings, nor recall the factory settings.
- (2) Select the desired bank (M1, M2, etc.) using the [M-]/[M+] pistons.
The number of the selected bank appears in the upper left corner of the display:



Press [M-] to select the previous bank, and [M+] to select the next bank.

- (3) Press and hold the [SET] piston.

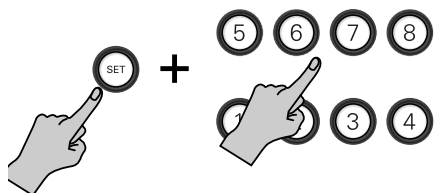

- (4) While continuing to hold [SET], press the piston of the general memory where you wish to save the new registration.
- (5) Release both pistons. The new registration is now stored ("Function Complete") and can be recalled by simply pressing that piston (after selecting the right "M" bank).

Saving settings to a divisional memory

- (1) Select the desired stops, and couplers for the manual whose settings you want to store.
This can be the upper (MAN II) or lower (MAN I) manual.
- (2) Press and hold the [SET] piston.

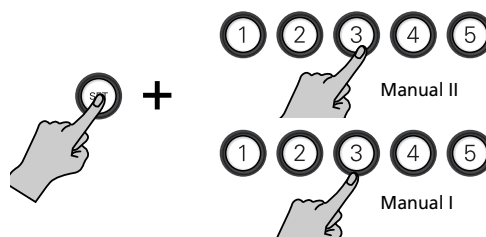

- (3) While continuing to hold [SET], press the piston where you wish to save the new registration.
Press a memory piston in the upper row to save the MAN II registration. Press a piston in the lower row to save a MAN I registration.
- (4) Release both pistons. The new registration is now stored ("Function Complete") and can be recalled by simply pressing that piston.

Suggestion for using the banks

Settings stored in one bank don't affect those stored in other banks; each of the memories is independent.

Many organists keep regularly-used registrations, such as those used for hymns, in one bank and use other banks for preludes, postludes and choral accompaniments, which may change week to week.

A variety of useful registrations are included with your new 538/i548.

Selecting a memory

Selecting a general memory



- (1) Select the desired bank (M1, M2, etc.) using the [M-]/[M+] pistons.
The number of the selected bank appears in the upper left corner of the display:





While no memory number is displayed, the 538/i548 goes on using the settings in effect up to that point.

- (2) Press the piston that contains the settings you wish to use.
The number of the selected memory appears to the right of the selected bank.



If the new memory you need is located inside the currently selected bank, you can also select it using the  or  piston.



Note: You cannot change banks with the / pistons (i.e. go from memory "8" of bank "1" to memory "1" of bank "2", etc.).

Selecting a divisional memory

- (1) Press the piston of the divisional memory you wish to load (be sure to use the piston of the desired manual).

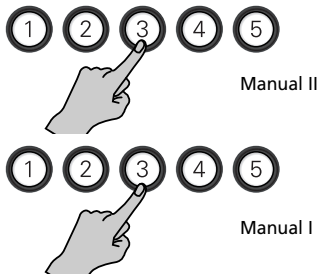

The piston of the selected memory lights.

Configuring the MANUAL I memories to include the PEDAL registration

The 538/i548 has five memory pistons for manual I, which can be configured to include the registrations of both manual I and the pedalboard.

For example, you could use a  piston of manual I to recall stops, couplers and MIDI settings on the PEDAL and MANUAL I divisions at once, or you could use a MANUAL I piston to change manual I's registration alone.

At the factory, the MANUAL I pistons  are configured to affect only manual I.

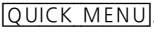
- (1) Press .
- (2) Use the Select knob to select "Console".



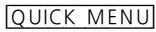

- (3) Confirm your choice by pressing . This takes you to a lower level with several options.

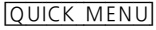

- (4) Select the "Divisional Piston" parameter.

- (5) Confirm your choice by pressing .



- (6) Rotate the data entry wheel to select "Manual I" (the divisional memories affect only manual I) or "Manual I + Pedal".
- (7) Save your setting if you wish to keep it. See "Saving general settings" on p. 42, or proceed as follows: Press and hold  +  for a few seconds while "Function Complete" is displayed.
- (8) When finished, press and hold the  piston to return to the main page (if necessary).

Expression/crescendo

The 538/i548 has one pedal that can be used to control the volume or the crescendo function.

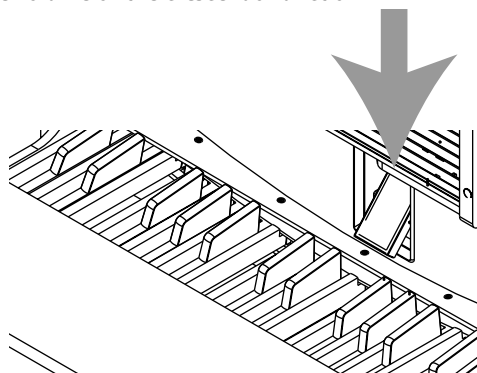

When the **CRESCENDO** tab is off, the expression shoe affects the volume ("expression" function). As long as you do not change the "Expression" setting (page 36), volume changes only affect manual II (upper manual).

When you press the **CRESCENDO** tab (so that it lights), the pedal acts as Crescendo pedal.

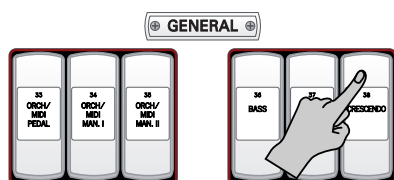

The Crescendo function adds more stops as you press the pedal further down, adding richness and depth to the sound. It does not affect the stops already in use on the organ, but merely adds to them. There are eight Crescendo steps, which are indicated by means of a bargraph:



Bargraphs indicating the Crescendo level set via the pedal.

The stops added with each Crescendo step are preset. To check your Crescendo step assignments:

- Move the pedal all the way up.
- Press **[0]** (all tabs go dark).
- Press **CRESCENDO** (so that it lights).
- Press the pedal down and note how the tab indicators (and the sound) change.

Tremulants

Tremulants create a change in amplitude (volume). They add warmth and expressiveness to solo or small ensemble combinations. It is not common to use tremulants in larger classical ensembles. In some romantic ensembles, tremulants are used judiciously. In some gospel and evangelical musical traditions, tremulants with a wider and deeper excursion are frequently used.

The 538/i548 provides two **TREMULANT** tabs, which affect only the stops in their respective division: **MAN I** (lower manual) and **MAN II** (upper manual).

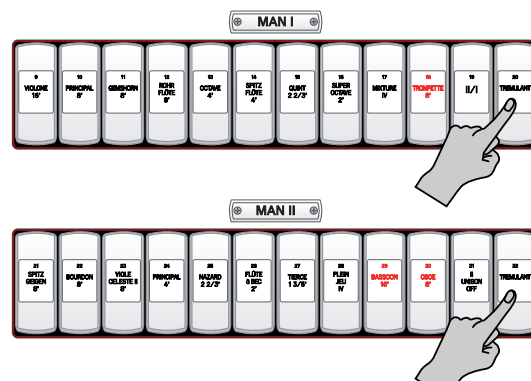

A tremulant is activated by pressing its tab (it will light). The tremulants can be stored with registrations in both general and corresponding divisional memories.

Note: Each tremulant can be modified to suit your taste and needs. See page 33.

Tutti

There are times when a full organ registration is needed immediately. **Tutti** allows you to engage full organ quickly without canceling the current registration. To activate Tutti, press the **TUTTI** piston (it lights).



Press it again to turn Tutti off and return to the current registration. (You can also press **EXIT** to switch off the Tutti function.)

Transpose

The Transpose function allows you to change the key of the music played. Commonly, this is used to accommodate a soloist (or instrumentalist who prefers to play an accompaniment in a different key than what is written) or to easily raise or lower the pitch of a hymn. The transposition interval is normally shown in the display ("Transpose" value). If another screen appears in the display (i.e., while programming a specific parameter), you can easily return to this page by pressing and holding **EXIT**.

While the master page is displayed, the transposition interval can be changed using the Select knob (-6~+5 semitones).

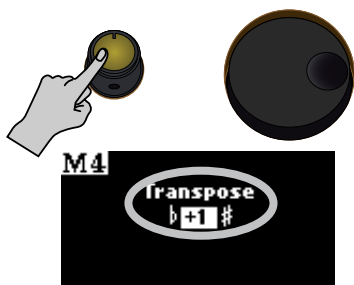

About stop families

Organ stops are grouped into four main families: Principals, Flutes, Strings and Reeds. Each of these families is well represented on your Rodgers instrument.

The **Principal** family is the group of stops unique to the organ, they aren't imitative of other instruments. Principals are often referred to as the "backbone" of the organ and play a strong role in hymn accompaniments and as the foundation of many chorus registrations. Examples of stops belonging to the Principal family are **Principal, Octave, Super Octave, Choralbass** and **Prestant**.

In addition, mixture stops, with names such as **Mixture** and **Plein Jeu**, consist of multiple Principal ranks; the Roman numeral following the name denotes the number of ranks contained in the mixture. For example, a **Mixture IV** tab contains four ranks of Principal pipes.

The **Flute** family consists of stops that are generally imitative of orchestral flutes and recorders. This is an extremely diverse group of stops which function in a myriad of ways, from acting as a solo color to serving as the basis of ensemble registrations, either by themselves or in combination with other stops. Examples of flute stops are **Bourdon** and **Gedackt**.

String stops do exactly what you would imagine—they imitate the sound of orchestral strings. These ranks are smaller in scale than most other ranks and usually have a lot of upper harmonics and a "clean" or "silvery" timbre. This characteristic makes them well suited to accompaniment and softer ensembles. String stops include **Violone, Violin Diapason**, and **Viola Celeste II**. Members of the **Reed** family are also very diverse and are used for everything from solo colors to the fiery crown in a full organ registration. These stops, also, are often imitative of orchestral reeds and brass instruments. Examples of reed stops are **Trumpet, Trompette**, and **Trumpet**.

Other families

In addition to the four families of stops listed above, your 538/i548 also has a few other stop families that can be used by selecting orchestral sounds.

There are also percussive instrument voices such as **Piano** and **Timpani**. These stops have a percussive attack and gradually grow softer as you hold the note. Unlike many other systems, the decay of notes played on the Chimes isn't affected by changes in the registration.

Also present in the 538/i548 specification are voices in the orchestral and choral families. Examples of orchestral colors include the **Slow Strings** and **Warm Strings**; choral voices are represented by **Real Choir** and **Choir Fem** textures.

Pitch designations

The tabs on your 538/i548 each have a pitch designation, listed in "feet", (8', 4', 16', etc.). **8'** refers to *concert pitch*; a note played on an 8' stop will have an identical pitch as the same note played on a piano. **16'** represents an octave *below* concert pitch; a note played on a 16' stop will sound an octave below an 8' stop.

This system of designating pitches represents the approximate length of open organ pipes; the largest pipe in an 8' rank is approximately eight feet long; the largest pipe in a 16' rank is about sixteen feet long. Other footages and their relationship to concert pitch are listed in the table below:

Pitch	Relationship to concert pitch
32'	two octaves below
16'	one octave below
8'	equal to concert pitch (also known as "Unison")
4'	one octave above
2'	two octaves above
1'	three octaves above

When whole numbers are used (as shown in the table above), it implies that the pitch of the stop is a certain number of octaves above or below the 8' pitch.

Mutation stops, on the other hand, are different in that they have fractions in their pitch designations. This means that their pitch falls somewhere other than on the octave.

Mutation	Common name	Relationship to concert pitch
2-2/3'	Nazard	one octave and a fifth above
1-3/5'	Tierce	two octaves and a third above
1-1/3'	Quintflöte	two octaves and a fifth above

Mutations are most commonly found in the flute family and are often used with other flute stops in solo registrations or ensembles used in early organ music. Because mutations often appear in divisions with a number of other flute stops, a great diversity of solo color can be achieved by using various combinations of stops. See the following table for common solo registrations utilizing mutations.

Registrations using mutations with other flute stops

8'	4'	2-2/3'	2'	1-3/5'	1-1/3'
•		•			
•	•				•
•	•	•			
•	•			•	
•	•	•	•	•	

Larger organs will often have one or two mutation stops from the principal family. In most cases, these ranks are used to add color to the principal chorus.

Celeste ranks

Celestes are unique among organ stops in that they are intentionally tuned sharp or flat in relation to the rest of the instrument. Celestes are paired with a partner rank (often called a "unison"), which is similar in color to the celeste rank but is in tune with the balance of the organ.

When the unison and celeste are drawn together, the tuning discrepancy between the two ranks creates a beautiful undulating quality suitable for lush, romantic textures. Celestes are either from the string or flute family, with the latter usually being the quieter of the two.

ORCH/MIDI couplers

The ORCH/MIDI couplers on the 538/i548 allow the organist great flexibility and creativity with tonal resources beyond pipe organ stops.

The ORCH/MIDI couplers are in fact tabs that allow you to access the internal orchestral voices, or to control sounds and settings of an external MIDI device.

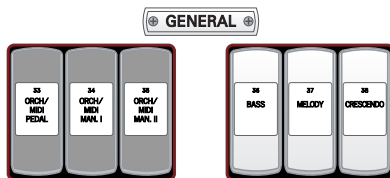

Orchestral couplers (ORCH)

The 538/i548 has a large number of orchestral voices accessible through these tabs. The orchestral voices can be played in isolation or together with organ stops. See the list at the end of this manual for the available orchestral voices.

See page 34 for details about selecting orchestral sounds and the settings you can change.

MIDI couplers

The MIDI couplers on the 538/i548 transmit digital commands between the keyboards and a MIDI sound module, allowing you to use additional sounds and effects or record your music using an external "sequencer" (MIDI recording device/software). See page 44 for more information.

3. Using the 538/i548's recorder

The 538/i548 contains a "Song Recorder" function you can use to record your own performances. The 538/i548's internal memory can contain one such song. If you use a USB storage device, however, you can save (and play back) as many songs as the device will hold.

Recording a song

Here's what you need to do to record your performance:

- (1) Set the 538/i548's divisions to your liking by activating all required tabs and pistons.

WARNING: If you already recorded another song since switching on the 538/i548, that song will be erased without warning when you perform the next step. To keep that song, you need to save it before continuing. See "Saving your song" below. (If you performed that operation after your first recording, there is nothing you need to do before proceeding.)

Also note that your last recording (in the temporary) is erased when you switch off the 538/i548.

- (2) Press the  piston (it flashes).



The display now looks as follows:



- (3) If necessary, use the Select knob to select the "♩=" value (tempo) or the time signature ("4/4" in the illustration above) and set the desired value with the data entry wheel.

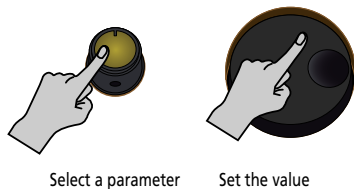



The setting range for the tempo is ♩ = 20~250. The time signature can be 2/2, 1/4~7/8, 3/8, 6/8, 9/8 or 12/8.

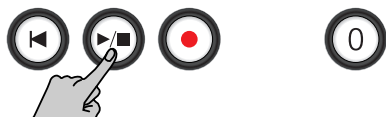

Note: Be sure to set the correct time signature, because you cannot change it at a later stage.

- (4) Press the  piston to start recording.



The metronome counts down one measure, and recording starts (the  and  pistons light).

Note: See page 26 for the available metronome parameters.

- (5) Start playing.
- (6) Press  again at the end of the song.
- (7) Press the  piston to return to the beginning of the song.

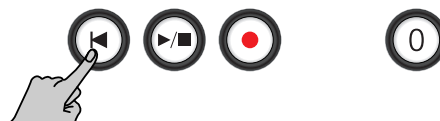

- (8) Press  yet again to listen to your recording. If you like your recording, remember to save it (see below). If you want to redo it, return to step (2) above.

Saving your song

At first, the 538/i548 uses a temporary memory (called "RAM") for the data you record. That memory is erased when you redo your recording and when you switch off the 538/i548. Therefore, you need to save the recordings you like using the following procedure.

You can save your data either to the internal memory (one song) or to an optional USB data storage device.

- (1) Press the  piston.

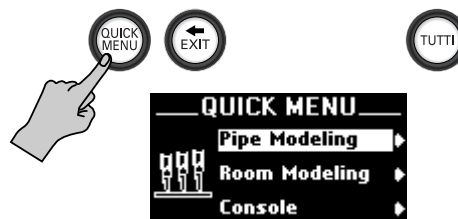

- (2) Use the Select knob to select the "Song Recorder" entry:

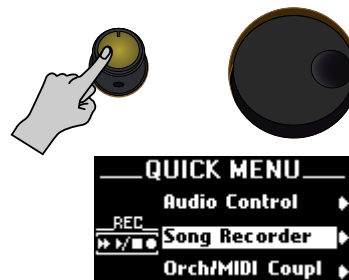

- (3) Press the  piston to confirm your choice.

Note: If you select the wrong entry, you can return to the previous level by briefly pressing the  piston.

- (4) Use the Select knob to select "Save Song".



- (5) Press the [QUICK MENU] piston.



- (6) Use the Select knob to select "Internal Mem" (the internal song memory) or "USB Memory" (an optional USB storage device).
If you want to save your song to a USB storage device, connect it to the USB port below the data entry wheel.



Connect your USB storage device here. →

Note: You can only use USB storage devices that have been formatted on the 538/i548. If your device is brand-new, see page 42 for how to format it. This operation has no effect on your recording.

- (7) Press the [QUICK MENU] piston to confirm your choice.

If you selected "Internal Mem"

The display now looks as follows:



- (8) Press the [+] piston to save your song.
The display now shows:



The internal memory can only hold one song. If it already contains one, the following warning is displayed.



- (9) Press the [+] piston to save your new song (and replace the previous one, which will be lost). If you wish to keep the previous song, press [-]. The display returns to the previous page, and your song is not saved. To keep it, repeat the procedure, but choose "USB Memory" in step (6).
(10) Press and hold the [EXIT] piston to return to the main page.



If you selected "USB Memory"

If the following is displayed, connect your USB storage device to the 538/i548's USB port and press the [+] piston.



The display now looks as follows:



This page allows you to name your song (up to 8 characters).

- (8) Use the Select knob to move the cursor (the white square) left or right.
(9) Select the desired character with the data entry wheel.
(10) Press the [+] piston to save your song.
The display now shows:



If the USB storage device's memory capacity is exhausted, the following warning appears and your song is not saved:



- (11) Press and hold the [EXIT] piston to return to the main page.



Playing back songs

You can play back the song stored in the 538/i548's internal memory as well as songs on a USB storage device.

Given that you can work with external USB storage devices, you might be tempted to copy Standard MIDI Files to that device (using your computer, for instance) and play them back using the 538/i548. The 538/i548 does not conform to the GS standard or General MIDI format. Songs not specifically prepared with/for the 538/i548 (or older Rodgers organs of the 5xx series) will not sound as expected.

But you can record your performance with a 538/i548 in one location and then play it back using a 538/i548 in a different location simply by connecting your USB storage device to the other 538/i548 and proceeding as follows.

- (1) Press the [QUICK MENU] piston.

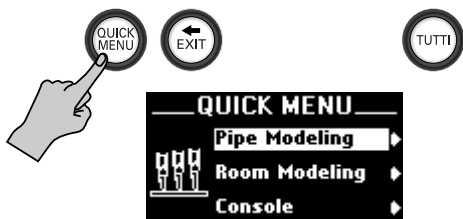

- (2) Use the Select knob to select the "Song Recorder" entry:

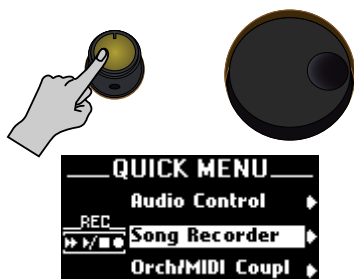

- (3) Press the [QUICK MENU] piston to confirm your choice.

Note: If you select the wrong entry, you can return to the previous level by briefly pressing the [EXIT] piston.

- (4) Use the Select knob to select "Select Song".



- (5) Press the [QUICK MENU] piston.



- (6) Use the Select knob to select "Internal Mem" (the internal song memory) or "USB Memory" (an optional USB storage device).

If you want to play back a song on a USB storage device, connect it to the USB port below the data entry wheel.



Connect your USB storage device here.

Note: You can only use USB storage devices that have been formatted on the 538/i548. If your device is brand-new, press and hold [EXIT] and see page 42 for how to format it.

- (7) Press the [QUICK MENU] piston to confirm your choice.

If you selected "Internal Mem"

The display now looks as follows:



As there is only one internal memory...

- (8) Press the [▶/■] piston to start playback. The display jumps to the following page (with the tempo value already selected). If you like, you can use the data entry wheel to change the tempo ("♩=").



- (9) Press the [▶/■] piston again to stop playback.
- (10) To listen to the song from the beginning, first press the [◀] piston, then [▶/■] to start playback.

- (11) Press and hold the  piston to return to the main page.



If you selected "USB Memory"



If the following is displayed, connect your USB storage device to the 538/i548's USB port and press the  piston.

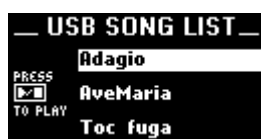

The display now looks as follows:







Note: If you disconnect the USB storage device, the above list will be empty (the song titles disappear).

- (8) Use the Select knob to select the song you want to listen to.
- (9) Do one of the following:
- Press  to start playback. —or—
 - Press the  piston to load the song into the 538/i548's temporary memory. Note that this will erase the song that may already be there. Next, press  to start playback.

The display jumps to the following page (with the tempo value already selected). If you like, you can use the data entry wheel to change the tempo ("♩=").



- (10) Press the  piston again to stop playback.
- (11) To listen to the song from the beginning, first press the  piston, then  to start playback.
- (12) Press and hold the  piston to return to the main page.

Metronome and count-in

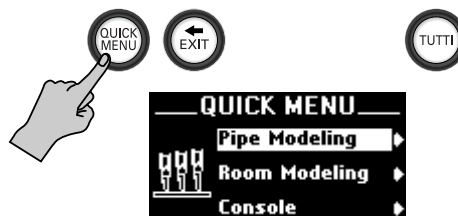

The 538/i548 provides a versatile metronome function. You can adjust the volume or beat of the metronome and specify when the metronome should sound. There is also a "REC Count-In" function that can be set to count down one or two measures before recording starts. See p. 15 for details about the metronome.

- (1) Press the  piston.



- (2) Use the Select knob to select the "Song Recorder" entry:



- (3) Press the  piston to confirm your choice.
- Note:** If you select the wrong entry, you can return to the previous level by briefly pressing the  piston.
- (4) Use the Select knob to select "REC Count-In".

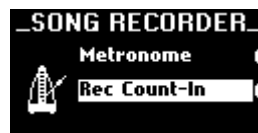

- (5) Press the  piston.



- (6) Use the data entry wheel to make your choice:
- 1 Measure The metronome counts in one measure before recording starts.
 - 2 Measures The metronome counts in two measures (i.e. 8 beats when the time signature is set to "4/4").
- (7) Save your settings if you wish to keep them. Normally, these settings are temporary and are lost when the organ is powered off. If desired, a save procedure of these parameters can be performed, which causes the new settings to be retained when the organ is turned off. See "Saving general settings" on p. 42.
- (8) When finished, press and hold the  piston to return to the main page.

Deleting songs

The 538/i548 allows you to delete song files (your own recordings) you no longer need. Though you can also delete the song in the internal memory, doing so is probably unnecessary, because it is erased each time you save a new recording to the 538/i548's internal memory.

- (1) Press **[QUICK MENU]**.
- (2) Use the Select knob to select "Song Recorder".



- (3) Confirm your choice by pressing **[QUICK MENU]**. This takes you to a lower level with several options.
- (4) Choose "Delete USB Song" with the Select knob.



- (5) Confirm your choice by pressing **[QUICK MENU]**. If the following is displayed, connect your USB storage device to the 538/i548's USB port and press the **[QUICK MENU]** piston.



WARNING: Songs you delete cannot be restored. If your USB storage device is already connected, the display now looks as follows:



Note: If you disconnect the USB storage device, the above list will be empty (the song titles disappear).

- (6) Use the Select knob to select the song you want to delete ("Adagio" in the example above).
- (7) Press the **[+]** piston to delete the song. The display briefly confirms this action ("Function Completed").
- (8) Press and hold the **[← EXIT]** piston to return to the main page.



4. Other functions

This chapter presents the capabilities of the 538/i548 in greater detail. Use it to become more familiar with the many innovative features of your fine Rodgers instrument.

Console display and controls

The 538/i548 is equipped with a graphic display with an intuitive "Quick Menu" structure for many of the console functions described in this section. The display normally indicates the transposition ("Transpose"), and memory bank/memory ("M") settings. But there are other functions you can set, including MIDI settings, Tremulant rate and depth, and many others.

Three controls are used to select the features found in the display: **[QUICK MENU]** is used to activate menu mode and confirm the selection of items. By selecting a menu item, you go to a lower level. **[EXIT]** is used to return to the previous level (when pressed briefly), or to the main page (when held down).

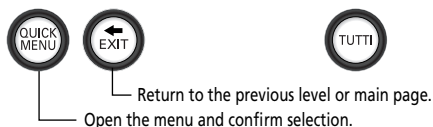

The **Select** knob is used to select items. As stated above, your selection needs to be confirmed by pressing the **[QUICK MENU]** piston. The **data entry wheel** is used to change the settings of the selected parameter.



The following section describes how the console display is used, outline the basic navigation techniques and gives you a map of what can be found and set by the organist. After that, each control found in the display will be described in more detail.

Accessing organ control functions

Most console functions can be accessed in the following way:

- (1) Press **[QUICK MENU]**.
- (2) Use the **Select knob** to select a menu heading.
The following menu sections are available:

Pipe Modeling*	Orch/MIDI Coup*
Room Modeling*	MIDI Setting*
Console	Orchest Setting*
Audio Control*	Memory Setup
Song Recorder	Demo Songs
- (3) Confirm your choice by pressing **[QUICK MENU]**. This takes you to a lower level with several options.
- (4) Choose an item with the **Select knob**.
- (5) Confirm your choice by pressing **[QUICK MENU]**.
- (6) Change the setting with the **data entry wheel**. The next step depends on what you want to do next:
- (7) Do one of the following:

To use your setting and start playing:	Press and hold [EXIT] until the master page appears.
To set another item or save your settings:	Briefly press [EXIT] and repeat steps (2)~(6).

- (8) **Save your settings if you wish to keep them.**
Normally, these settings are temporary and lost when the organ is powered off. If desired, a save procedure of the "Quick Menu" parameters can be performed, which causes the new settings to be retained when the organ is turned off. See "Saving general settings" on p. 42.
- (9) When finished, press and hold the **[EXIT]** piston to return to the main page.

Setting the display's contrast and brightness

All Quick Menu parameters are accessed via the display, which means that you may need to adjust its contrast for better visibility. There is a second parameter that allows you to specify how long the display should remain lit after setting a parameter.

- (1) Press **QUICK MENU**.



- (2) Use the Select knob to select "Console".
 (3) Confirm your choice by pressing **QUICK MENU**.
 This takes you to a lower level with several options.



- (4) Choose "LCD" with the Select knob.



- (5) Confirm your choice by pressing **QUICK MENU**.



- (6) Use the Select knob to choose "Contrast" and set the desired dark/light balance with the data entry wheel.

"0" means that the characters and icons are almost as dark as the background. "127" means that the background is almost as light as the characters.

Select the settings you find most comfortable.

- (7) Use the Select knob to choose "Light Off" and choose one of the following settings with the data entry wheel:

Disabled	The display never goes off.
10Sec	The display goes dark after 10 seconds of inaction (i.e. if no other parameter is selected or set).
15Sec	The display goes dark after 15 seconds of inaction.
20Sec	The display goes dark after 20 seconds of inaction.

As you see, the display behaves like a digital photo camera or mobile phone if you select one of the "Secs" settings. It will come on each time you press the **QUICK MENU** piston.

- (8) Save your setting if you wish to keep it.

See page 42, or press and hold **SET** + **0** for a few seconds.

- (9) When finished, press and hold the **EXIT** piston to return to the main page.

Quick Menu parameters

The following table lists control parameters and settings that can be adjusted after pressing the **QUICK MENU** piston.

PIPE MODELING		
Tremulant I*	Depth	0~127
	Rate	0~127
	Pitch	0~12
Tremulant II*	Depth	0~127
	Rate	0~127
	Pitch	1~12
Temperament*	Type	Equal, Mean-Tone, Pythagorean, Kirnberger, Werckmster I, Werckmster III, Young I, Young II
	Key	C, C#, D, D#, E, F, F#, G, G#, A, A#, B
Valve Release* ^a	Value	OFF, 1~8
Random Tuning*	Value	-7~8
ROOM MODELING		
Room Size*	Set	Small Hall, Small Church, Room, Stage, Medium Hall, Medium Church, Large Church, Cathedral
Wall Type*	Set	Drapery, Carpet, Acoustic Tile, Wood, Brick, Plaster, Concrete, Marble
Ambience Level*	Set	0~127
CONSOLE		
Master Tuning*	Set	Locked A= 440, Adjustable, Manual Only
Expression*	Division	Manual II, Manual II + Manual I, Manual II + Pedal, All
	Low Value	Normal, ppp, pppp
Memory Bank*	Set	Locked, Unlocked
Divisional Piston*	Set	Manual I, Manual I + Pedal
Stop Configuration	Set	User, Baroque, American, English, French
LCD*	Contrast	0~127
	Light Off	Disabled, 10 sec, 15 sec, 20 sec
USB Format	USB Format	
AUDIO CONTROL		
Master Volume*	Value	0~127
Division Volume*	Division	Pedal, Manual I, Manual II
	Volume	0~127
Aux In Volume*	Value	0~127
Output Volume*	Assign	Internal, External
	Volume	0~127
Output Panpot*	Assign	Internal, External
	Panpot	-64~63
Main Channel*	Assign	Internal, External
	Set	On, Off
Altern Channel*	Assign	Internal, External
	Set	On, Off
Ambience Return*	Assign	Front Left, Front Right, Rear Left, Rear Right
	Set	Off, Intern Left, Intern Right, Extern Left, Extern Right
AUX Channel*	Assign	Internal, External
	Set	On, Off
Ambience Level*	Assign	Main, Alternate, Aux
	Value	0~127

Internal Equalizer*	High Freq	Freq	2000, 3000, 4000, 5000, 6000, 7000, 8000, 9000, 10000, 11000, 12000 (Hz)
		Gain	-15~+15 (dB)
	Middle Freq	Freq	200, 250, 315, 400, 500, 630, 800, 1000, 1250, 1600, 2000, 2500, 3150, 4000, 5000, 6300, 8000 (Hz)
		Gain	-15~+15 (dB)
		Mid Q	0.5, 1.0, 2.0, 4.0, 8.0
	Low Freq	Freq	50, 80, 100, 150, 200, 250, 300, 400 (Hz)
		Gain	-15~+15 (dB)
	EQ Switch	Set	On, Off
EQ Gain	Value	-15~+3 (dB)	
EQ Level	Value	0~127	
External Equalizer*	High Freq	Freq	2000, 3000, 4000, 5000, 6000, 7000, 8000, 9000, 10000, 11000, 12000 (Hz)
		Gain	-15~+15 (dB)
	Middle Freq	Freq	200, 250, 315, 400, 500, 630, 800, 1000, 1250, 1600, 2000, 2500, 3150, 4000, 5000, 6300, 8000 (Hz)
		Gain	-15~+15 (dB)
		Mid Q	0.5, 1.0, 2.0, 4.0, 8.0
	Low Freq	Freq	50, 80, 100, 150, 200, 250, 300, 400 (Hz)
		Gain	-15~+15 (dB)
	EQ Switch	Set	On, Off
EQ Gain	Value	-15~+15 (dB)	
EQ Level	Value	0~127	
SONG RECORDER			
Select Song	Internal Memory	One internal song	
	USB Memory	Any song stored there	
Save Song	Internal Memory	One song	
	USB Memory	Depending on the capacity	
Delete USB Song	USB Memory	Any song stored there	
Metronome	Setting*	Off, On, REC	
	Volume*	0~127	
	Tempo	♩ = 20~250	
	Time Signature	2/2, 1/4, 2/4, 3/4, 4/4, 5/4, 6/4, 7/4, 3/8, 6/8, 9/8, 12/8	
Rec Count In*	Set	Off, 1 Measure, 2 Measures	
ORCH/MIDI COUPL			
Orch/MIDI Coupl°	Pedal	MIDI, Orch	
	Manual I	MIDI, Orch	
	Manual II	MIDI, Orch	
MIDI SETTING			
Pedal°	Channel	3	
	Prg	1~128	
	MSB	0~127	
	LSB	Off, 0~127	
	Reverb	0~127	
	Panpot	-64~63	
	Chorus	0~127	
	Octave	Down2, Down1, Normal, Up1, Up2	
	Velocity	KBD, EXP, 2~127	
	Foot Switch	Off, Sustain, Sost, Soft	
	Expression	Off, Volume, Expression	
	Local	On, Off	

Manual I°	Channel	1, 4~11, 15 & 16	
	Prg	1~128	
	MSB	0~127	
	LSB	Off, 0~127	
	Reverb	0~127	
	Panpot	-64~63	
	Chorus	0~127	
	Octave	Down2, Down1, Normal, Up1, Up2	
	Velocity	KBD, EXP, 2~127	
	Foot Switch	Off, Sustain, Sost, Soft	
	Expression	Off, Volume, Expression	
	Local	On, Off	
Manual II°	Channel	2	
	Prg	1~128	
	MSB	0~127	
	LSB	Off, 0~127	
	Reverb	0~127	
	Panpot	-64~63	
	Chorus	0~127	
	Octave	Down2, Down1, Normal, Up1, Up2	
	Velocity	KBD, EXP, 2~127	
	Foot Switch	Off, Sustain, Sost, Soft	
	Expression	Off, Volume, Expression	
	Local	On, Off	
General ¹	Master Channel	OFF, RCV ONLY, SEND ONLY, SEND & RCV	
	Seq.Update	On, Off	
	Device ID	1, 17~32	
	Stop Change	Receive	Off, Stops, Pistons, Stops & Pistons
Send		Off, Stops, Pistons, Stops & Pistons	
ORCHEST SETTING			
Pedal°	Instr	Acoustic Bass, Contrabbasso, Cello, St. Orch. Br., Pizzicato, Bassoon, Tuba, Timpani	
	Volume	0~127	
	Velocity	KBD, 2~127	
	Foot Switch	Off, Sustain, Sost, Soft	
Manual I°	Instr	Piano, Harp, Nylon Guitar, St. Strings, Warm Strings, Slow Strings, Real Choir, Chimes	
	Volume	0~127	
	Velocity	KBD, 2~127	
	Foot Switch	Off, Sustain, Sost, Soft	
Manual II°	Instr	Violin, Flute, Oboe, Trumpet, Brass, French Horn, Harpsichord, Choir Fem	
	Volume	0~127	
	Velocity	KBD, 2~127	
	Foot Switch	Off, Sustain, Sost, Soft	
MEMORY SETUP			
Factory Set	MIDI Parameters		
	Memory Set		
	General Parameters		
Parameters Save	MIDI Parameters	Internal Memory	
		USB Memory	
	Memory Set	USB Memory	
	General Parameters	Internal Memory	
USB Memory			

Parameters Load	MIDI Parameters	USB Memory
	Memory Set	USB Memory
	General Parameters	USB Memory
DEMO SONGS		
1 All Songs		
2 New Song		
43 ...10		

a. A voicing adjustment for the Rodgers Dealer/Installer. It is recommended not to change this setting.

*: Saved with "Gen Param Save"
 †: Saved with "MIDI Param Save"

°: Saved to a registration memory

Tuning

The 538/i548 is set to standard concert pitch (A=440.0Hz). However, it can easily and quickly be tuned flat or sharp to match the pitch of another musical instrument, such as a piano or harp.

In instruments augmented with pipes, the tuning feature can be used to bring the electronics in tune with the pipes or other acoustic instruments. The 538/i548 retains this setting when it is turned off.

The "Quick Menu" contains a "Master Tune" parameter that allows you to specify whether and how the 538/i548's tuning can be changed.

- (1) Press **[QUICK MENU]**.
- (2) Use the Select knob to select "Console".



- (3) Confirm your choice by pressing **[QUICK MENU]**. This takes you to a lower level with several options.
- (4) Choose "Master Tuning" with the Select knob.



- (5) Confirm your choice by pressing **[QUICK MENU]**.



- (6) Select the desired option with the data entry wheel.

Locked A= 440	The 538/i548 uses the tuning reference for electronic instruments (A4= 440Hz) and cannot be tuned (see below).
Adjustable	The pitch can be adjusted using the data entry wheel or via an externally connected MIDI device.
Manual Only	The pitch can be adjusted only with the data entry wheel.

- (7) Save your setting if you wish to keep it. See page 42, or proceed as follows: Press and hold **[SET] + [0]** for a few seconds.
- (8) When finished, press and hold the **[← EXIT]** piston to return to the main page.

The current tuning setting appears in the display:



As there are now two parameters you can set, you need to use the **data entry wheel** to change the "Tune" setting, and the **Select knob** to change the "Transpose" value (if necessary). These two parameters can be changed without pressing **[QUICK MENU]**.

Tremulant controls

The first section of this manual (see page 19) described how tremulants are activated, what stops they control and how they are often used. Another impressive feature of the 538/i548 are the **user-adjustable Tremulants**. Although the tremulants are carefully set at the factory and adjusted when the organ is voiced, the rate and depth may be modified for each to meet a particular musical need or suit an individual taste.

Adjusting tremulant settings

- (1) Press **[QUICK MENU]**.
- (2) Use the Select knob to select "Pipe Modeling".



- (3) Confirm your choice by pressing **[QUICK MENU]**. This takes you to a lower level with several options.



- (4) Select the "Tremulant I" or "Tremulant II" parameter.



This depends on whether you wish to change the behavior of the **TREMULANT I** tab in the MANUAL I or MANUAL II section.

You can also select this page by holding down **SET** while pressing **TREMULANT I** or **TREMULANT II**.

- (5) Select the "Depth" (intensity), "Rate" (speed), or "Pitch" (detune) parameter.
- (6) Confirm by pressing the **QUICK MENU** piston.
- (7) Use the data entry wheel to set the desired value. The setting range is 0~127 for both "Depth" and "Rate", and 1~12 for "Pitch". Setting "Depth" to "0" means that the tremulant effect is inaudible ("127" represents to strongest effect). Similarly, setting "Rate" to "0" means that the modulation is extremely slow, while "127" is probably way too fast for most applications. The higher the "Pitch" value you select, the stronger the pitch fluctuations.
- (8) Save your setting if you wish to keep it. See page 42, or proceed as follows: Press and hold **SET** + **0** for a few seconds.
- (9) Press and hold the **EXIT** piston to return to the main page.

Using orchestral sounds

The 538/i548 has a large number of internal Orchestral voices accessible through tabs labeled **ORCH/MIDI PEDAL**, **ORCH/MIDI MAN.I** or **ORCH/MIDI MAN.II**. These orchestral voices are listed below. The orchestral voices can be played alone or together with organ stops. Only one orchestral voice per division can be played at a time.

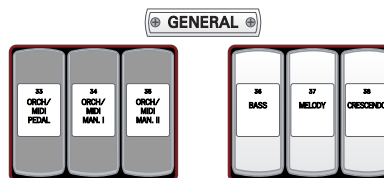

Orchestral voices played on manual II and manual I are velocity-sensitive, but orchestral voices played on the Pedalboard are not. All voices are programmed to sustain if the sustain footswitch (next to the expression shoe) is activated and all orchestral voices are affected by the expression shoe. This can be changed, however (see below).

The organ tremulants do *not* affect the orchestral voices. Orchestral voices are unavailable if an ORCH/MIDI coupler is set to "MIDI". MIDI parameters, such as "Octave", "Chorus", etc., do not affect orchestral voices. Velocity and the footswitch, on the other hand, apply both to the orchestral voices and MIDI messages.

Selecting orchestral voices

- (1) Press and hold the **SET** piston.

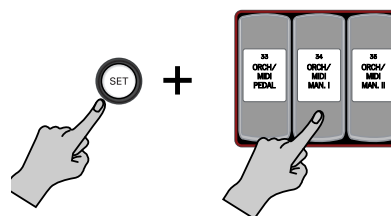

- (2) Press the lower part of an **ORCH/MIDI** tab (it lights).
- (3) Release the **SET** piston.
- (4) Rotate the data entry wheel until the name of the desired orchestral voice appears in the display. This setting needs to be saved to a general or divisional memory.
- (5) Press and hold the **EXIT** piston to return to the main page.

Settings for the orchestral sounds

The 538/i548 contains three parameters that can be set for each orchestral sound separately. They allow you to set the volume, to specify whether or not the orchestral sound in question should be velocity sensitive, and how it should behave when the 538/i548's sustain footswitch is used.

(1) Press **[QUICK MENU]**.

(2) Use the Select knob to select "Orchest Setting".



(3) Confirm your choice by pressing **[QUICK MENU]**. This takes you to a lower level with several options.



(4) Use the Select knob to select the division that contains the orchestral sound whose behavior you want to change.

The parameters discussed below can be set for all available orchestral sounds (choose them one after another). For reasons of clarity, they are grouped according to the divisions they are assigned to.

The following orchestral sounds are available:

PEDAL	MANUAL I	MANUAL II
Acoustic Bass	Piano	Violin
Contrabbasso	Harp	Flute
Cello	Nylon Guitar	Oboe
St Orch. Br.	St. Strings	Trumpet
Pizzicato	Warm Strings	Brass
Bassoon	Slow Strings	French Horn
Tuba	Real Choir	Harpsichord
Timpani	Chimes	Choir Fem

(5) Confirm your choice by pressing **[QUICK MENU]**.



(The information displayed depends on the division you selected.) You can also select this page directly by holding down the **[SET]** piston while pressing the ORCH/MIDI COUPLER tab of the division whose setting you want to change.

(6) Use the Select knob to choose the sound ("Tone") whose settings you want to change (see the list above).

(7) Use the data entry wheel to select the sound.

(8) Use the Select knob to select another parameter you want to set.

The possibilities are: "Vol" (volume), "Vel" (velocity) and "FtSw" (footswitch).

(9) Use the data entry wheel to set the desired value.

Vol 0~127

Vel KBD, 2~127

Fixed Velocity (2~127): The keyboard sends a fixed value between "2" and "127".

Keyboard velocity (Kbd): The keyboard responds to velocity of your fingers.

FtSw Off, Sustain, Sost, Soft

Sust(ain): Also called "Damper" or "Hold", the footswitch allows you to hold the notes you play on the keyboard in much the same way as on an acoustic piano.

Sost(enuto): The footswitch sustains only the notes of the keys that were already pressed when you pressed the pedal.

Soft: When you hold the footswitch and play the keyboard, the orchestral sound will have a softer tone.

Note: Each time you switch on the organ, the "FtSw" parameter is reset as follows: ORCH PEDAL and ORCH MAN II= "Off" for all sounds, ORCH MAN I= "Sust" for all sounds. To return to your assignments at that stage, simply select a memory.

This setting needs to be saved to a general or divisional memory.

(10) Press and hold the **[EXIT]** piston to return to the main page.

Using the ROOM MODELING effect

The sound we normally hear allows us to perceive the distance from the sound source because it is a combination of two different types of sounds: The sound that reaches our ears directly and the sound that reaches us with some delay after it reflects off of walls and other surfaces. A component of Dimensional Sound Modeling, the "Rodgers Room Modeling" system allows you to specify the acoustic you desire for the 538/i548. "Room Modeling" does more than add simple decay to the sound of the instrument, it uses leading-edge technology to go beyond three-dimensional sound and create a sense of distance, shape and ambience to what is heard in the room.

The ROOM MODELING menus allow you to specify the size of the room and type of wall covering for the 538/i548 acoustic. For example, if you wanted to hear the instrument in a large room, you could select "Cathedral"; if you wanted to change the wall covering from a soft to a hard material, you could select "Marble".

Selecting an effect type and fine-tuning its settings

The kind of reverb ("Room Size") effect is selectable. Proceed as follows to select a different type:

- (1) Press **[QUICK MENU]**.
- (2) Use the Select knob to select "Room Modeling".



- (3) See page 28 for the various ways of selecting the "Room Size" parameter of the ROOM MODELING group.



- (4) Use the Select knob to select "Room Size".
- (5) Confirm your choice by pressing **[QUICK MENU]**. This takes you to a lower level with several options.



- (6) Use the data entry wheel to select the desired "Room Size". The possibilities are: Small Hall, Small Church, Room, Stage, Medium Hall, Medium Church, Large Church, Cathedral.

- (7) If you also want to set the other ROOM MODELING parameters ("Wall Type" and "Ambience Level"), proceed as follows:
 - Briefly press **[EXIT]** to return to the "Room Modeling" menu level.



- Use the Select knob to select "Wall Type" or "Ambience Level".



- Confirm by pressing the **[QUICK MENU]** piston.
 - Use the data entry wheel to select the desired setting. See page 30 for the available settings.
- (8) Save your setting if you wish to keep it. See page 42, or proceed as follows: Press and hold **[SET] + [0]** for a few seconds.
 - (9) Press and hold the **[EXIT]** piston to return to the main page.

Expression function

The 538/i548 comes with one expression shoe that can be used for swell effects (increasing/decreasing the volume), or for controlling the Crescendo effect (page 19).

Note: You cannot combine the expression and Crescendo functions.

The minimum volume of each division when its expression shoe is closed can be adjusted to suit specific musical needs or personal tastes. There are three expression settings. These settings affect the volume of the division when the expression shoe is completely closed.

This feature is analogous to adjusting the thickness of expression shutters on a pipe organ; the thicker the shutters, the less sound transmitted when the expression shoe is closed. In all cases, the settings do not affect the sound when the expression shoe is open.

- (1) Press **[QUICK MENU]**.
- (2) Use the Select knob to select "Console".



- (3) Confirm your choice by pressing **[QUICK MENU]**. This takes you to a lower level with several options.

- (4) Use the Select knob to select "Expression".



- (5) Confirm your choice by pressing [QUICK MENU]. This takes you to a lower level with several options.



- (6) Use the Select knob to select the "Divis" parameter.
 (7) Use the data entry wheel to select the desired setting.

Manual II:	Only manual II is affected by the expression pedal's position. (This is the default setting.)
Manual II + Manual I:	Both manual II and manual I are affected by the expression pedal's position.
Manual II + Pedal:	Manual II and the pedalboard.
All:	Manual I + manual II + pedals

- (8) Use the Select knob to choose the "Low Value" parameter.
 (9) Use the data entry wheel to select the desired setting.

The possibilities are:

Normal	When the expression pedal is in the up position (minimum value), the sections selected above are inaudible. (This is the default setting.)
ppp	When the expression pedal is in the up position (minimum value), the sections selected above are much softer than usual.
pppp	When the expression pedal is in the up position (minimum value), the sections selected above are very soft.

- (10) Save your settings if you wish to keep them.

See page 42, or proceed as follows: Press and hold [SET] + [0] for a few seconds.

Note: This is a global setting that applies to all individual memories.

- (11) When finished, press and hold the [EXIT] piston to return to the main page.

Temperaments

In recent years, there has been a renewed interest in authentic interpretation of organ literature written before the adoption of Equal Temperament tuning. Until the middle of the 18th century, the relative pitches of the notes of the scale were chosen to favor music written in key signatures with few sharps or flats. More remote keys produced varying degrees of aural distress. Many composers of the day utilized moderately out of tune intervals to evoke momentary

tension to the listener. With the adoption of the Equal Temperament (well-tempered) tuning system, almost universal today, all keys became equally out of tune and the intentions of these earlier composers were lost, to some degree.

The 538/i548 offers a choice of eight temperaments. The selection of one of these temperaments allows the organist to hear historical works as their composers heard them, or to explore the application of unequal temperament to new music.

Ancient temperaments

Mean-Tone: Mean-Tone temperament improves on the Pythagorean tuning (see below) by slightly contracting each of the four fifths needed to generate a major third. Major thirds and in-tune fifths are slightly narrow and the differences between the major and minor seconds are smoothed out. Many artists now prefer Mean-Tone temperaments when performing 15th- through 17th-century repertoire.

Pythagorean: Pythagoras (582~500 B.C.) was a brilliant Greek theorist and mathematician. The Pythagorean temperament is characterized by pure fifths and fourths. The Pythagorean theory founded a diatonic scale that served as a model throughout the Middle Ages.

J.S. Bach's *Well Tempered Clavier*, written in 1722 and between 1738 and 1742, is a collection of 24 paired preludes and fugues written in every major and minor key. The title refers to the use of a temperament in which all keys are satisfactorily in tune, but not necessarily an absolutely equal temperament.

Well temperaments

Kirnberger: Johann Philipp Kirnberger (1721~1783) was a German composer and pupil of Bach from 1739 and 1741. His temperament favored pure fifths, as in the Pythagorean model, but performance was improved in many keys.

Werckmster and WerckmstIII : Andreas Werckmeister experimented with temperaments in the latter part of the 17th century. In Werckmeister I, he further refined the Mean-Tone temperament. In Werckmeister III, four tones are practically tuned identical to Equal Temperament (C, D#, F# and A).

Young I & II: Young Temperaments offer further refinements to the Mean-Tone model, except with slightly higher-pitched sharps.

Equal: Equal Temperament is the modern standard that uses a succession of 12 semitones of equal size, allowing performance in all keys successfully. The fifths are slightly narrowed and the upward thirds are considerably sharp, but unlimited modulation from key to key is possible.

Selecting a temperament

- (1) Press **[QUICK MENU]**.
- (2) Use the Select knob to select "Pipe Modeling".



- (3) Confirm your choice by pressing **[QUICK MENU]**. This takes you to a lower level with several options.



- (4) Choose "Temperament" with the Select knob.
- (5) Confirm your choice by pressing **[QUICK MENU]**.

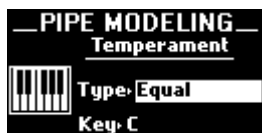

(The "Type" parameter is already selected. To return to this parameter after setting "Key", use the Select knob.)

- (6) Use the data entry wheel to select the desired temperament. See above for the possibilities. For all temperaments (except "Equal"), you also need to specify in what key you will be playing:
- (7) Use the Select knob to choose the "Key" parameter.
- (8) Use the data entry wheel to select the desired key. The possibilities are: C, C#, D, D#, E, F, F#, G, G#, A, A#, B.
- (9) Save your settings if you wish to keep them. See "Saving general settings" on p. 42, or proceed as follows: Press and hold **[SET] + [0]** for a few seconds.
- (10) Press and hold the **[← EXIT]** piston to return to the main page.

Note: When the organ is turned off, the temperament reverts to "Equal", the default setting. Also, the instrument can be quickly returned to the "Equal" temperament by pressing **[0] + [SET]**. This procedure also returns MIDI parameters to their factory settings.

Random tuning

One of the essential ingredients of a pipe organ ensemble arises from the small amount of pitch deviation in each pipe. No matter how carefully an instrument is tuned, small changes in temperature or humidity cause the pipes to drift slightly from their original pitches. Reed pipes are especially prone to drift in tuning because of cyclic temperature variations.

The "Random Tuning" feature causes random notes to receive a small amount of detuning. The amount of detuning is chosen at random for each note of each voice. Some notes are not detuned at all. The number of notes detuned and the maximum amount of detuning are selected for each voice to mimic the behavior of an equivalent pipe set. For instance, reeds exhibit more pitch fluctuation than flutes. Because the detuning is random, there is no degradation of the overall temperament of the instrument and the amount of detuning is no more than one would experience in a recently tuned pipe instrument.

This detuning process happens each time the organ is turned on. Once computed, the pitch of each note remains constant. Thus, the tuning of the instrument is a little different each time it is powered on, as it would be with a pipe organ. The amount of random detuning can be set as follows:

- (1) Press **[QUICK MENU]**.
- (2) Use the Select knob to select "Pipe Modeling".



- (3) Confirm your choice by pressing **[QUICK MENU]**. This takes you to a lower level with several options.
- (4) Select the "Random Tuning" parameter.



- (5) Confirm your choice by pressing **[QUICK MENU]**.



- (6) Rotate the data entry wheel to select the desired value (-7~+8).
- (7) Save your setting if you wish to keep it. See "Saving general settings" on p. 42, or proceed as follows: Press and hold **[SET] + [0]** for a few seconds. **Note:** In order to hear this new detune setting, you need to save it, and switch the 538/i548 off and back on again.
- (8) When finished, press and hold the **[← EXIT]** piston to return to the main page.

Valve Release

On a pipe organ, the end of each note (when a key is released) the reeds fall in pitch, which is more or less audible on different instruments. The 538/i548's "Valve Release" parameter allows you to simulate this phenomenon ("8" represents the most noticeable effect), or to switch it off.

- (1) Press **QUICK MENU**.
- (2) Use the Select knob to select "Pipe Modeling".



- (3) Confirm your choice by pressing **QUICK MENU**. This takes you to a lower level with several options.
- (4) Choose "Valve Release" with the Select knob.



- (5) Confirm your choice by pressing **QUICK MENU**.



- (6) Use the data entry wheel to select the desired setting. The possibilities are: OFF, 1~8.
- (7) Save your settings if you wish to keep them. See "Saving general settings" on p. 42, or proceed as follows: Press and hold **SET** + **0** for a few seconds.
- (8) Press and hold the **EXIT** piston to return to the main page.

Selecting the stop configuration

One of the 538/i548's amazing features is the possibility to revoice it completely for different applications or regional preferences. This can be done either manually (by programming the voicing parameters yourself, see the separate "Installation Manual") or simply by selecting another stop configuration. In this section, we'll show you how to select one of the preset voicings.

- (1) Press **QUICK MENU**.



- (2) Use the Select knob to select "Console".
- (3) Confirm your choice by pressing **QUICK MENU**. This takes you to a lower level with several options.



- (4) Choose "Stop Config" with the Select knob.



- (5) Confirm your choice by pressing **QUICK MENU**.
- (6) Select the desired option with the **data entry wheel**.

User	A voicing prepared by your Rodgers dealer or yourself (based on the parameters discussed in the separate "Installation Manual") and saved to this memory.
------	---

Baroque, American, English, French	Voicings that cater to the needs of various musical traditions.
------------------------------------	---

- (7) Save your selection if you wish to keep it. See page 42, or press and hold **SET** + **0** for a few seconds. Saving this setting means that the 538/i548 will select this voicing again next time you switch it on. No other voicing-related settings are saved here, because they need to be performed in a different mode.
- (8) When finished, press and hold the **EXIT** piston to return to the main page.

Volume settings

Master Volume

Special situations and individual preferences sometimes require a temporary change in the overall volume of the organ. The 538/i548's overall volume can be set in two ways.

- (1) Adjust the **GENERAL VOLUME** knob located on the black input/output box underneath the keydesk to the right.

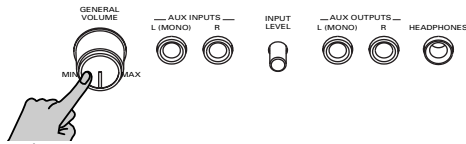

...and/or...

- (2) Press **QUICK MENU**.
- (3) Use the Select knob to select "Audio Control".



- (4) Confirm your choice by pressing **QUICK MENU**.
- (5) Choose "Master Volume" with the Select knob.



- (6) Confirm your choice by pressing **QUICK MENU**.



- (7) Use the data entry wheel to select the desired setting.
The setting range is: 0~127.
- (8) Save your settings if you wish to keep them.
See "Saving general settings" on p. 42, or press and hold **SET** + **0** for a few seconds.
- (9) Press and hold the **EXIT** piston to return to the main page.

Changing the balance of the divisions

If you think that the balance between the PEDAL, MANUAL I and MANUAL II divisions is not quite right, because one is much softer/louder than the others, you can use one of the following parameters to correct that.

The quickest way is usually to single out the division whose volume needs correcting, and to change only that. Otherwise, you may end up spending a lot more time than originally planned.

- (1) Press **QUICK MENU**.
- (2) Use the Select knob to select "Audio Control".



- (3) Confirm your choice by pressing **QUICK MENU**.
- (4) Choose "Division Volume" with the Select knob.



- (5) Confirm your choice by pressing **QUICK MENU**.



- (6) Use the Select knob to choose "Division".
- (7) Use the data entry wheel to select the division whose volume you want to correct.
The possibilities are: Pedal, Manual I, Manual II
- (8) Turn the Select knob to move to the "Volume" entry.
- (9) Use the data entry wheel to set the desired volume for the division you selected in step (7).
- (10) Use the Select knob to choose the desired setting.
The setting range is: 0~127. Obviously, it would be a good idea to play on the three keyboards to test your new balance.
- (11) Save your settings if you wish to keep them.
See "Saving general settings" on p. 42, or press and hold **SET** + **0** for a few seconds.
- (12) Press and hold the **EXIT** piston to return to the main page.

Audio inputs and outputs

The 538/i548 is equipped with stereo auxiliary input sockets (one for the left channel and one for the right channel) located on the connector panel to the right under the keydesk. Audio signals from other sound-generating devices like synthesizers, MIDI sound modules and tape players are mixed into the organ's main audio system.

The balance between external signal sources and the 538/i548's sounds can be set by increasing or decreasing the output level of the device connected to the AUX INPUTS L (MONO)/R sockets, the **INPUT LEVEL** knob on the connector panel, or with the parameter discussed below.

Connect the AUX OUTPUT L (MONO)/R sockets to an external amplifier or audio recording device.

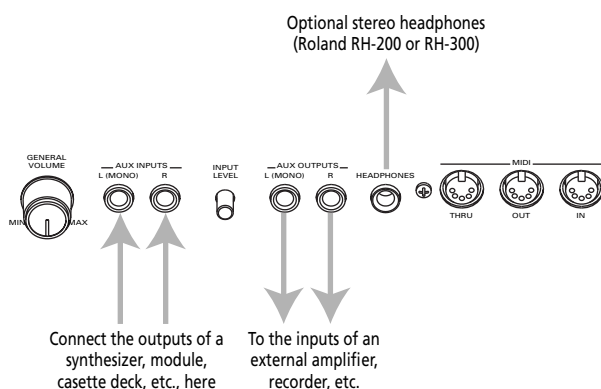

Public address systems should **NOT** be connected through the organ's audio system.

- (1) Press **QUICK MENU**.
- (2) Use the Select knob to select "Audio Control".



- (3) Confirm your choice by pressing **QUICK MENU**.



- (4) Choose "AUX In Volume" with the Select knob.
- (5) Confirm your choice by pressing **QUICK MENU**.



This parameter can also be set using the **INPUTS LEVEL** knob.

- (6) Use the data entry wheel to set the desired volume for signals received via the AUX INPUTS sockets. The setting range is: 0~127.

- (7) Save your settings if you wish to keep them. See "Saving general settings" on p. 42, or press and hold **SET** + **0** for a few seconds.
- (8) Press and hold the **EXIT** piston to return to the main page.

Other AUDIO CONTROL parameters

The 538/i548's "Audio Control" environment contains a lot more parameters than are discussed here. They can be selected in the same way as the parameters described so far. We nevertheless recommend not to change them unless you have a sound understanding of how they affect the sound. Ask your Rodgers dealer to set them for you, because you may never want to change them.

- Output Volume*** Volume of the signals transmitted to the LINE OUT sockets.
- Output Panpot*** Stereo placement of the signals transmitted to the LINE OUT sockets.
- Main Channel*** Audio routing of two MAIN channels. The 538/i548's sound can be reproduced via four channels: 2x MAIN (front) and 2x ALTERNATE (rear).
- Altern Channel*** Audio routing of two ALTERNATE channels.
- Ambience Return*** Audio routing of Ambience Return, i.e. the outputs of the Room Modeling processor.
- AUX Channel*** Audio routing of the AUX INPUTS signals.
- Ambience Level*** Allows you to change the output level of the Room Modeling (a.k.a. Ambience) processor.
- Internal Equalizer*** A 3-band equalizer for the internal signals (the ones reproduced by the 538/i548's speakers).
- External Equalizer*** A 3-band equalizer for the external signals (the ones reproduced by external speakers you connect to the 538/i548).

Saving general settings

Changes to the "Audio Control" level of the "Quick Menu" parameters are temporary, i.e., they are lost when the organ is turned off. If desired, however, your settings can be saved to a special memory (which is not related to the registration memories).

Note: Your MIDI settings are not saved during this procedure. See page 54 for how to save your MIDI settings.

- (1) Press **[QUICK MENU]**.
- (2) Use the Select knob to select "Memory Setup".



- (3) Confirm your choice by pressing **[QUICK MENU]**. This takes you to a lower level with several options.
- (4) Use the Select knob to select "Parameter Save".



- (5) Confirm your choice by pressing **[QUICK MENU]**. This takes you to a lower level with several options.
- (6) Choose "GeneralParam" with the Select knob.



- (7) Confirm your choice by pressing **[QUICK MENU]**.
- (8) Use the Select knob to select "Internal Mem" (internal memory) or "USB Memory" (external storage device).



If you want to save your settings to a USB storage device, connect it to the 538/i548's USB port (below the data entry wheel).

- (9) Confirm your choice by pressing **[QUICK MENU]**. **Note:** The 538/i548 has one "General Parameters" memory whose contents will be overwritten the next time you save your menu settings. That is why you also have the option to save your settings to a USB storage device.

Depending on what you select, the display now looks like this...



Press the **[+]** piston to save your settings internally.

...or like this:



- Use the Select knob to move the cursor (the white square) left or right.
- Select the desired character with the data entry wheel.
- Press the **[+]** piston to save your settings.

- (10) Press and hold the **[EXIT]** piston to return to the main page.

The "General Parameters" settings are now saved and will be retained when the organ is turned off.

Formatting a USB storage device

The 538/i548 allows you to save all storable settings to a USB device.

General considerations

The 538/i548's USB port is intended for use with a compact storage device. They are practical, because they fit even in the smallest pocket, so that you can take "your" 538/i548 settings with you and use them on other Rogers 538/i548 organs. Be aware, however, that compact storage devices are not the safest storage medium around. We therefore recommend making a safety copy ("backup") of the stick's contents on your computer's hard disk: simply connect the storage device to a free USB port on your computer and copy its contents to a suitably named directory ("538 Data", for example). Though your computer cannot read the data, it can nevertheless store them.

Note: Do not connect the 538/i548 to a USB hub. Always connect it directly to your storage device.

Note: The 538/i548 cannot be connected to a computer (the computer will not recognize it).

Note: The 538/i548's USB port cannot be used for MIDI applications.

Formatting procedure

Before being able to save data to a USB storage device, you need to **format it on the 538/i548**.

- (1) Connect your USB storage device to the 538/i548's USB port.



Connect your USB storage device here. →

- (2) Press **QUICK MENU**.



- (3) Use the Select knob to select "Console".
 (4) Confirm your choice by pressing **QUICK MENU**.
 This takes you to a lower level with several options.



- (5) Choose "USB Format" with the Select knob.



WARNING: Formatting your USB storage device means that all data it contains will be erased. You may want to connect USB storage device to your computer first to check and/or copy contents.

- (6) If you are absolutely positive about formatting the USB storage device, press the **[+]** piston.
 (Press **[←] EXIT** to abort the operation.)

Formatting the USB storage device may take a short while, during which the display shows the following message:



Never switch off the 538/i548 or remove the USB storage medium (or the USB cable to which it is connected) while this message is displayed.
 Always wait until the "Function Completed" message is displayed.

- (7) When finished, press and hold the **[←] EXIT** piston to return to the main page.

5. MIDI functions

Rodgers organs have powerful MIDI capabilities, offering remarkable possibilities for musical performance. MIDI, which is an acronym for "Musical Instrument Digital Interface", is a digital protocol for transmitting and receiving music and sound data. It allows the user to access the capabilities of another MIDI compatible device, such as a MIDI sound module or a MIDI sequencer.

The MIDI couplers on the 538 transmit digital commands between the keyboards and a MIDI sound module, allowing you to use additional sounds and effects, or record your music using an external "sequencer" (MIDI recording device/software). MIDI devices can be connected to the connector panel to the right underneath the keydesk.

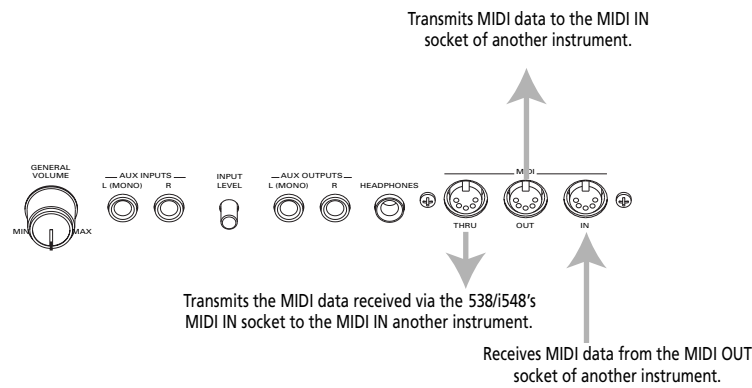

MIDI couplers

The MIDI couplers are activated by tabs labeled **ORCH/MIDI PEDAL**, **ORCH/MIDI MAN.I** and **ORCH/MIDI MAN.II**.

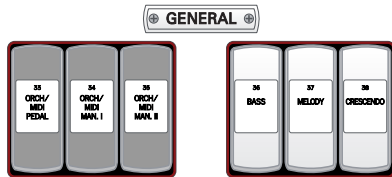

The tabs are labeled "ORCH/MIDI" because they can be used as *either* MIDI couplers *or* orchestral couplers. The tabs must be configured as MIDI couplers to access and play MIDI sounds on an external MIDI source.

Enabling MIDI

To set an ORCH/MIDI tab as a MIDI coupler:

- (1) Hold down the **[SET]** piston and press the upper half of the **[ORCH/MIDI]** coupler that is assigned to the division whose MIDI settings you wish to change. The tab you pressed flashes and the 538/i548's "Quick Menu" appears, with the parameter of the keyboard in question already selected.

You can also select that page by pressing the **[QUICK MENU]** piston, using the Select knob to select "ORCH/MID COUPL" and pressing **[QUICK MENU]** again.



- (2) Change the setting ("Orch" or "MIDI") with the data entry wheel. Select "MIDI" for all divisions that should be in MIDI mode.
- (3) If necessary, use the Select knob to select another division and change its definition with the data entry wheel.
- (4) Press and hold the **[EXIT]** piston to return to the main page. The MIDI settings and the ORCH/MIDI tab status (on or off) can be saved to the MIDI memory area. See page 54.

MIDI settings

Each coupler also has a number of parameters accessible through the "MIDI Setting" menu (see page 31) and provides great flexibility in the way a sound is controlled. These parameters are:

Parameter	Description
Channel	Specifies the MIDI channel used by the coupler (MIDI GREAT can be changed)
Prg/Msb/Lsb	Specify the sound or effect controlled by the MIDI coupler.
Reverb	Specifies the amount of reverb for the sound
Panpot	Specifies the location of a sound within the stereo field
Chorus	Specifies the amount of chorus for the sound
Octave	Specifies the octave of the sound; octave can be shifted up or down
Velocity	Specifies whether a sound has a fixed velocity (or attack) or whether the velocity is affected by movements of the expression shoe or the force of fingers when actual notes are played
Local	allows you to break the connection between the division in question and the 538/i548's internal tone generator.

Each of these parameters will now be discussed in more detail.

MIDI Channel

Each of the 538/i548 MIDI couplers can control a different sound or MIDI channel of an external instrument. This is accomplished by using **separate MIDI channels**. Because the channels are independent, the instruments can be controlled individually.

The MANUAL I MIDI coupler normally sends on MIDI channel 1. However, it can be set to transmit on 1, 4~11, 15 or 16. The channels for other couplers are fixed.

Following are the MIDI coupler tabs and their MIDI channels:

Division	Coupler	MIDI channel
Pedal	ORCH/MIDI PEDAL	3
Manual I	ORCH/MIDI MAN I	1*
Manual II	ORCH/MIDI MAN II	2

(*) May be changed to MIDI channels 4, 5, 6, 7, 8, 9, 10, 11, 15, 16

Changing Manual I's MIDI channel

Generally, you won't need to change the MIDI channel of the Manual I division to use most MIDI sound modules. However, there may be times when it is necessary or desirable to send MIDI information on a channel other than "1".

Common reasons for changing the MAN I MIDI coupler channel include accessing sounds in a module that receives on a set MIDI channel.

- (1) Press **[QUICK MENU]**.
- (2) Use the Select knob to select "MIDI Setting".



- (3) Confirm your choice by pressing **[QUICK MENU]**.

- (4) Choose "Manual I" with the Select knob.



- (5) Confirm your choice by pressing **[QUICK MENU]**.



- (6) If "Channel" is not selected, use the Select knob to activate its value for input.
- (7) Use the data entry wheel to set the required MIDI channel number.
- (8) Save your settings if you wish to keep them. See page 54.
- (9) Press and hold the **[EXIT]** piston to return to the main page.

Note: The MANUAL I MIDI coupler channel assignment can be saved with other settings to a registration memory.

Tone (Prg, Msb, Lsb)

These parameters select the instrument (or 'tone'), which is heard when the MIDI coupler is activated and keys are pressed on the appropriate manual or pedalboard.

Selecting a MIDI tone (address) via a keyboard shortcut

- (1) First of all, set the desired ORCH/MIDI tab coupler(s) to "MIDI" rather than "ORCH". Please refer to "Enabling MIDI" on p. 44.
- (2) Press and hold the **[SET]** piston.
- (3) Press the upper half of the desired ORCH/MIDI tab (PEDAL, MAN I or MAN II).

It flashes to signal that a MIDI setting can be made. If you press the ORCH/MIDI MAN.I tab, the display looks as shown in step (5) on p. 45. The page for the MAN.II and PEDAL couplers looks similar, the only exception being that you cannot change their MIDI channel number.

(If that page is not displayed, turn the Select knob towards the left until you see the "Prg", "Msb" and "Lsb" parameters.)

- (4) Enter the number for the desired tone ("Prg"). See the tone chart provided with the sound module: Press the corresponding key on the MAN.I, MAN.II or PEDAL manual. (A quick-reference keyboard tone chart is provided with the owner's manual of the Rodgers PR300S sound module/sequencer.)

Program numbers 1~61 are sent by the MAN.I keys, 62~122 by the MAN.II keys and 123~128 by the PEDAL division. Once a key is pressed, the ORCH/MIDI tab stops flashing (and the light remains on) and the display returns to the master page.

The tone selection procedure is complete. This MIDI selection may now be saved if desired.

- (5) Release the key and the **[SET]** piston.
- (6) Save your settings if you wish to keep them. See page 54.
- (7) Press and hold the **[←EXIT]** piston to return to the main page.

Selecting a MIDI tone by number

If desired, you can select tones in external MIDI sound modules by number, rather than name. This powerful technique ensures that the 538/i548 can select tones in any sound module that follows the MIDI standard.

When selecting a tone in an external MIDI sound module, the organ sends up to three separate MIDI messages: a *Program Change* message ("Prg") and one or two *Bank Select* (or "variation") messages ("Msb" and/or "Lsb"). When selecting tones by name, as outlined in the section above, these messages are generated automatically; when you select an instrument, the appropriate Program Change and Bank Select messages are sent.

When selecting a tone by number, you select sounds by entering of the actual MIDI messages, the Program Change and the Bank Select numbers.

Before selecting a tone by number, you'll need to determine the appropriate values for Program Change and Bank Select by referring to the charts that were provided with your sound module.

- (1) First of all, set the desired ORCH/MIDI tab coupler(s) to "MIDI" rather than "ORCH". Please refer to "Enabling MIDI" on p. 44.
- (2) Press and hold the **[SET]** piston.
- (3) Press the upper half of the desired ORCH/MIDI tab (PEDAL, MAN I or MAN II).

It flashes to signal that a MIDI setting can be made. If you press the ORCH/MIDI MAN.II tab, the display looks as shown in step (5) on page 45. The page for the MAN.II and PEDAL couplers looks similar, the only exception being that you cannot change their MIDI channel number.

(If that page is not displayed, turn the Select knob towards the left until you see the "Prg", "Msb" and "Lsb" parameters.)

- (4) Look up the number for the desired tone (Program Change) in the tone chart provided with the sound module.
- (5) Use the Select knob to select "Prg".
- (6) Rotate the data entry wheel to set the number for the desired tone.
- (7) To set the Bank Select MSB (CC00), use the Select knob to select "Msb".
- (8) Rotate the data entry wheel to select the bank number.
- (9) To set the Bank Select LSB (CC32), use the Select knob to select "Lsb".
- (10) Rotate the data entry wheel to select the bank number.
- (11) Save your settings if you wish to keep them. See page 54.
- (12) Press and hold the **[←EXIT]** piston to return to the main page.

Saving a tone address in a registration memory

Once a MIDI sound has been selected for a MIDI coupler tab, the same Program Change and Bank Select messages are sent each time the coupler piston is activated. A selected MIDI sound on a MIDI coupler tab can be saved for immediate recall.

- (1) Select a sound address for the desired ORCH/MIDI coupler, using the procedure above.
- (2) Press and hold the **[SET]** piston, then press the piston assigned to the memory where the MIDI address of the desired sound is to be saved.
- (3) Release both pistons.

This will save the MIDI sound to the piston memory. If desired, you can also save organ registrations with MIDI sounds by activating stops and couplers between steps (1) and (2) above.

More about MSB and LSB messages

As stated above, "MSB" and "LSB" are "Bank Select" messages; they are acronyms for *Most Significant Bit* and *Least Significant Bit*. They are typically used to select variations of sounds. The reason that both are supported in the 538/i548 is that some manufacturers use MSB for Bank Select while others use LSB.

The GS Format and General MIDI2 standard, for example, uses MSB (CC00) for Bank Select. The General MIDI or GM, standard uses Program Changes only; no Bank Select messages are used.

Consult the owner's manual for your particular MIDI sound module if you have questions about what messages are used to select sounds.

General MIDI and GS Format

In the past, most MIDI sound modules provided a maximum of 128 sounds. These were selected via MIDI Program Change messages. Unfortunately, there were no standard sound assignments for those messages. For example, one sound module may have had a Trumpet on Program Change #39, yet another sound module would have Chimes on #39.

With the creation of General MIDI (GM), a standard list of 128 sounds was defined, each of which corresponds to one of the 128 available Program Change messages. The GS Standard honors that same standard list of GM sounds, but also allows access to *more* than those 128 sounds through the use of Bank Select messages (using the MSB commands). The GS Standard adds the ability to select up to 128 "Variations" of each of the 128 standard GM sounds, expanding the total number of possible sounds to 16,384.

For example, Program Change #1 in a GM module specifies **Piano 1**. A GS module will also have **Piano 1** for Program Change #1 but, in addition, can have 127 other variations of that particular sound.

The GM instruments are often referred to as "Bank 0" sounds; the GS variations of that sound will be in other Banks: Bank 8, Bank 16, etc.

Many manufacturers of MIDI sound modules have added—or will soon add—support for GS Format.

- (4) Save your settings if you wish to keep them. See page 54.
- (5) Press and hold the **[EXIT]** piston to return to the main page.

Octave

Normally, sounds controlled by MIDI couplers play at concert pitch; playing middle C on an organ keyboard with a corresponding MIDI coupler active will cause middle C to be heard. The "Octave" function allows you to shift sounds controlled by MIDI couplers up or down by one or two octaves. Each MIDI coupler can be shifted independently.

When controlling a single sound from a keyboard or pedal, Octave Shift allows the instrument to play in a range that may be more appropriate; for example, you can shift a Tuba down one octave so that it plays at a more normal pitch.

Shifting the octave of a MIDI coupler up or down by octaves:

- (1) First of all, set the desired ORCH/MIDI tab coupler(s) to "MIDI" rather than "ORCH". Please refer to "Enabling MIDI" on p. 44.
- (2) Press and hold the **[SET]** piston. (You can also press **[QUICK MENU]**, select "MIDI Setting", the division and the parameter.)
- (3) Press the upper half of the desired ORCH/MIDI tab (**PEDAL, MAN I** or **MAN II**). It flashes to signal that a MIDI setting can be made.

- (4) Use the Select knob to select the "Oct" parameter.



- (5) Rotate the data entry wheel to select the desired setting ("Dwn 2", "Dwn 1", "Nor", "Up 1" or "Up 2"). The "Oct" selection procedure is complete. Memories that are set while the MIDI coupler is activated, will also store the setting.
- (6) Save your settings if you wish to keep them. See page 54.
- (7) Press and hold the **[EXIT]** piston to return to the main page.

Velocity

MIDI note velocity controls the attack quality and loudness of MIDI sounds. It relates to the amount of force used by the organist when striking a key and ranges from "2" (extremely light) to "127" (extremely hard). In addition to obvious changes in volume at higher velocities, the timbral nature of sounds can also change, which usually also make the sound brighter.

Rodgers organs can transmit a constant (fixed) velocity value from the keyboard, a variable velocity value relative to the position of the expression shoe or a velocity value controlled by the actual force of the fingers.

Velocity control can be individually selected for each ORCH/MIDI tab.

To summarize:

- Fixed Velocity (1~127): The keyboard sends a fixed value between "1" and "127".
- Keyboard velocity (Kbd): The keyboard responds to velocity of your fingers.
- Expression Velocity (EXP): Velocity value is controlled by the position of the expression shoe.

Fixed Velocity (1~127)

With fixed velocity, the same velocity value is used for all notes played by a MIDI coupler. The velocity can be set to any value from "1" to "127".

It is often useful to use this parameter to adjust the overall volume and attack characteristic of sounds controlled via MIDI. Reducing the velocity value would make an instrument softer; increasing the value would make it louder.

- (1) First of all, set the desired ORCH/MIDI tab coupler(s) to "MIDI" rather than "ORCH". Please refer to "Enabling MIDI" on p. 44.
- (2) Press and hold the **[SET]** piston. (You can also press **[QUICK MENU]**, select "MIDI Setting", the division and the parameter.)
- (3) Press the upper half of the desired ORCH/MIDI tab (**PEDAL, MAN I** or **MAN II**).

- Use the Select knob to select the "Vel" parameter.



- Rotate the data entry wheel to select the desired setting (1~127).
The "Vel" setting procedure is complete.
- Save your settings if you wish to keep them.
See page 54.
- Press and hold the **EXIT** piston to return to the main page.

Keyboard velocity (Kbd)

"Kbd" allows the velocity value of each note to be determined by the actual physical force used when the key is played, just like a piano keyboard. The harder a key is pressed, the louder the note and sharper the attack. This is especially useful when controlling percussive instruments and/or when you want to use key velocity as a means of musical expression.

There are also a variety of velocity curves available which allow you to specify how sensitive the keyboards are.

Note: Organ stops are not affected by keyboard velocity and the pedals are not velocity sensitive.

- See the procedure above.
- In step (5), use the data entry wheel to select "Kbd" rather than a value.
- Save your settings if you wish to keep them.
See page 54.
- Press and hold the **EXIT** piston to return to the main page.

Expression Velocity (EXP)

With "EXP", the velocity value is determined by the position of the related expression shoe when the note is played. As the expression shoe is pushed further down, the velocity value of notes played increases; as the expression shoe is closed, the velocity value decreases.

In EXP mode, the volume value for the coupler is set to 127 ("full") and movements of the expression shoe *will not change* the MIDI volume message; only the expression value of notes played change. This means that notes which are held down will be unaffected by movement of the expression shoe—only new notes played will respond to changes in the shoe position. Instruments controlled by couplers set in EXP mode will typically be much louder when the expression shoe is pushed open, because both the volume and velocity are set to full.

- Set the desired ORCH/MIDI tab coupler(s) to "MIDI" rather than "ORCH". Please refer to "Enabling MIDI" on p. 44.
- See the procedure for "Fixed Velocity (1~127)" on p. 47.
- In step (5), use the data entry wheel to select "Kbd" rather than a value.
- Save your settings if you wish to keep them.
See page 54.
- Press and hold the **EXIT** piston to return to the main page.

Pan

MIDI sound modules that conform to the GM and GS Format standards support the "Pan" message, which allows you to place an instrument at a specific point within a stereo field. When the Pan message is set to "0", the instrument is located in the **center**.

Negative values (-1~-64) move the sound further to the left side of the stereo field. A value of "-64" denotes the instrument is as far **left** as possible.

Positive values (1~63) move the sound further right in the stereo field. A value of "63" denotes the instrument is as far **right** as possible.

Each MIDI coupler can have its own individual Pan value.

- First of all, set the desired ORCH/MIDI tab coupler(s) to "MIDI" rather than "ORCH". Please refer to "Enabling MIDI" on p. 44.
- Press and hold the **SET** piston.
(You can also press **QUICK MENU**, select "MIDI Setting", the division and the parameter.)
- Press the upper half of the desired ORCH/MIDI tab (**PEDAL, MAN I** or **MAN II**).
It flashes to signal that a MIDI setting can be made.
- Use the Select knob to select the "Pan" parameter.



- Rotate the data entry wheel to select the desired setting (-64~63).
The "Pan" setting procedure is complete.
- Save your settings if you wish to keep them.
See page 54.
- Press and hold the **EXIT** piston to return to the main page.

Reverb

An independent reverb level (from 0~127) may be set for each MIDI coupler.

- (1) See steps (1)~(3) above.
- (2) Use the Select knob to select the "Rev" parameter.



- (3) Use the data entry wheel set the desired reverb value.
- (4) Save your settings if you wish to keep them.
See page 54.

Settings that are saved while the MIDI coupler is activated also contain the reverb value.

- (5) Press and hold the **[EXIT]** piston to return to the main page.

Chorus

An independent chorus level (from 0~127) may be set for each MIDI coupler. Chorus adds a slight pitch fluctuation to a given sound. It is often used for guitar and electric piano tones.

- (1) See steps (1)~(3) under "Pan".
- (2) Use the Select knob to select the "Cho" parameter.



- (3) Use the data entry wheel set the desired chorus value.
- (4) Save your settings if you wish to keep them.
See page 54.

The chorus setting can be saved to a memory piston along with all other parameters.

- (5) Press and hold the **[EXIT]** piston to return to the main page.

Local

The "Local" parameter provides opportunities for some very unique MIDI setups, many of which will not be used by most organists. However, should the need arise, the control is available.

When a division is in the **Local On** condition, it operates normally. This is the default setting.

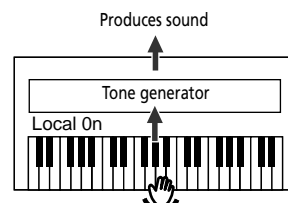

When a division is in the **Local Off** condition, the stops and keyboard (or pedals) of the selected division are disconnected from the internal ("local") sounds. This can be set for each division individually. Activating stops and playing notes won't result in any sound being heard from that division.

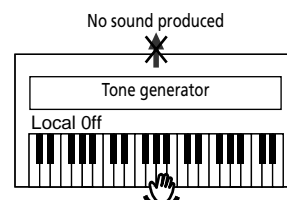

However, that division still transmits MIDI information that can be recorded or used to control another Rodgers organ. This feature can be used to silence the Master console completely when you wish to control only the external Rodgers console.

Also, in the Local Off condition, "local" divisions can still be played by a sequencer or remote keyboard connected to the MIDI IN jack; this means that the sounds of the 538/i548 can be controlled by a remote source even when "Local Off" is selected.

Finally, Local Off can be useful in specific sequencing applications when you are recording both organ and MIDI voices. To use it, MIDI Soft Thru must be enabled on your sequencer.

Each manual has its own "Local" parameter, so that you can decide, to assign only one keyboard to an external MIDI instrument.

- (1) Press **[QUICK MENU]**.
- (2) Use the Select knob to select "MIDI Setting".
- (3) Confirm your choice by pressing **[QUICK MENU]**.
- (4) Choose "Pedal", "Manual I", or "Manual II" with the Select knob.



- (5) Confirm your choice by pressing **[QUICK MENU]**.



- (6) Use the Select knob to choose the "Local" parameter.



- (7) Use the data entry wheel to select "On" or "Off".
 (8) Save your settings if you wish to keep them.
 See page 54.
 (9) Press and hold the **[EXIT]** piston to return to the main page.

- (5) Confirm your choice by pressing **[QUICK MENU]**.



- (6) Use the Select knob to choose the "FtSw" parameter.



- (7) Use the data entry wheel to select "Off" or one of the settings discussed above.
 (8) Save your settings if you wish to keep them.
 See page 54.
 (9) Press and hold the **[EXIT]** piston to return to the main page.

Footswitch and Expression parameters

The 538/i548's expression and sustain footswitch (next to the expression shoe can also transmit MIDI messages – again on different MIDI channels (one for each keyboard). The following parameters allows you to set their MIDI behavior.

Foot Switch

Use this parameter to specify (for manual I, manual II and the pedalboard) whether the sustain footswitch should transmit MIDI messages when pressed and which MIDI message it should send. Select "Off" if it should not transmit MIDI messages. Otherwise, select one of the following options:

- Sust(ain) Also called "Damper" or "Hold", the footswitch allows you to hold the notes you play on the keyboard in much the same way as on an acoustic piano.
- Sost(enuto) The footswitch sustains only the notes of the keys that were already pressed when you pressed the pedal.
- Soft When you hold the footswitch and play the keyboard, the sound on the external MIDI device will have a softer tone.

- (1) Press **[QUICK MENU]**.
 (2) Use the Select knob to select "MIDI Setting".
 (3) Confirm your choice by pressing **[QUICK MENU]**.
 (4) Choose "Pedal", "Manual I", or "Manual II" with the Select knob.



Expression

The MIDI language specifies two separate messages for setting the level of a tone: Expression (CC11) and Volume (CC07). It is possible to send either of these messages on a MIDI coupler when the corresponding shoe is moved. This setting can be made independently for each MIDI coupler.

Most newer MIDI modules respond to either message, causing changes in the level of a tone. In most MIDI applications, Volume (CC07) is used to set relative balances among the various parts while Expression (CC11) is used to create changes in the level of each part.

Because it was the first message of this type, the 538/i548's factory default specifies the Volume (CC07) message for all couplers; typically, this setting can be used with most MIDI sound modules. However, any coupler can be set to use the Expression (CC11) message if desired. If you don't want to send either Volume or Expression from the shoes for a given MIDI coupler, set this parameter to "Off".

- (1) Press **[QUICK MENU]**.
 (2) Use the Select knob to select "MIDI Setting".
 (3) Confirm your choice by pressing **[QUICK MENU]**.
 (4) Choose "Pedal", "Manual I", or "Manual II" with the Select knob.



- (5) Confirm your choice by pressing **[QUICK MENU]**.



- (6) Use the Select knob to choose the "Expression" parameter.



- (7) Use the data entry wheel to select "Off", "Vol", or "Exp".
- (8) Save your settings if you wish to keep them. See page 54.
- (9) Press and hold the **[EXIT]** piston to return to the main page.

When controlling the 538/i548 from an external MIDI keyboard, sending note information from the keyboard to the organ on a Master Channel will cause the respective keyboard or pedalboard to play. For example, sending notes on channel 12 will cause the same effect as playing those identical notes on the MANUAL I keyboard.

Enabling or disabling a MIDI Master channel

The status of each Master Channel can be set individually using the following procedure. Available options are: "Snd&Rcv" (send & receive, the normal mode), "SndOnly" (send), "RcvOnly" (receive) and "Off" (neither transmit, nor receive).

- (1) Press **[QUICK MENU]**.
- (2) Use the Select knob to select "MIDI Setting".
- (3) Confirm your choice by pressing **[QUICK MENU]**.
- (4) Choose "General" with the Select knob.



- (5) Confirm your choice by pressing **[QUICK MENU]**.



- (6) Use the Select knob to choose the "Master Ch" parameter.



- (7) Use the data entry wheel to select the desired option.
- (8) Save your settings if you wish to keep them. See page 54.
- (9) Press and hold the **[EXIT]** piston to return to the main page.

Global MIDI settings

In addition to the various MIDI parameters that can be stored relative to individual MIDI couplers, there are a number of global MIDI settings that affect the entire 538/i548.

All Notes Off

Occasionally, it is desirable to send a MIDI "All Notes Off" message from a keyboard to reset notes played by external equipment.

Press **[0] + [SET]**. An "All Notes Off" message will be sent on all 16 MIDI channels from the 538/i548's MIDI OUT port.

Master channel

Much of the discussion about MIDI so far has dealt with the actions of the MIDI couplers; those controls that allow you to play the instruments in an external MIDI sound module. However, the stops and divisions of the 538/i548 can also be recorded by a sequencer and played back, either with or without sounds from an external sound module.

In order to keep the sounds of the organ separate from those of a MIDI sound module, certain Master Channels have been reserved specifically for the 538/i548. One channel is reserved for each division:

PEDAL Channel	14
MANUAL I Channel	12
MANUAL II Channel	13

The 538/i548 sends and receives note and volume information on these channels unless they are disabled. Most likely, the Master Channels will always be enabled in your situation; however, there are a few unique setups where it might be desirable to suppress the transmission or reception of information for one or more organ divisions.

Registrations (Stop Change)

In addition to note and volume information sent on the Master Channels, the 538/i548 sends and receives MIDI information related to registrations. This information can be used to control the stops and couplers of a separate Rodgers organ or, more commonly, can be recorded by a sequencer (along with the note and volume information on the Master Channels) and then recreated during playback.

Registration information is normally transmitted and received in the form of System Exclusive (SysEx) messages. Each time there is a change in a stop or coupler, a SysEx message is generated by the organ that

gives the updated status of *all* stops and couplers. Each of these SysEx messages, then, communicates the status of the entire instrument.

If desired, the 538/i548 can transmit Program Changes when registration memories are selected on the organ. These messages only communicate which pistons are pressed, not the status of stops and couplers. This is often useful when controlling the 538/i548 from a remote MIDI keyboard that sends Program Changes or from a different model of Rodgers organ. The Program Changes are sent and received on one of the Master Channels.

System Exclusive messages, on the other hand, provide optimum control over registrations, both those made by pressing pistons and those changed by hand. Factory default settings of both "Send" and "Receive" are set to "Stops & Pist" (System Exclusive messages). Available options are: "Stops", "Pistons" (Program Change messages), "Stops & Pist", and "Off".

- (1) Press **[QUICK MENU]**.
- (2) Use the Select knob to select "MIDI Setting".
- (3) Confirm your choice by pressing **[QUICK MENU]**.
- (4) Choose "General" with the Select knob.



- (5) Confirm your choice by pressing **[QUICK MENU]**.



- (6) Use the Select knob to choose the "Rcv" (reception of "Stop Change" messages) or "Snd" (transmission of those messages), depending on what you want to set.



- (7) Use the data entry wheel to select the desired option.
- (8) Save your settings if you wish to keep them. See page 54.
- (9) Press and hold the **[EXIT]** piston to return to the main page.

Using pistons to control a second Rodgers organ

In cases where two Rodgers organs are available, it is possible to play either or both instruments from one location. In these setups, the controlling console is referred to as the "Master" and the console played from a remote location is known as the "Slave".

In order for the two consoles to communicate, a MIDI connection must be made between the MIDI OUT jack of the Master console and the MIDI IN jack of the Slave. (A number of third-party companies make special systems to transmit MIDI over long distances.)

Once this connection is made, the Master console can access the resources of the slave console. Most often, it is best to use pistons to control registrations at both locations; when a certain piston is pressed on the Master console, the same piston is selected at the Slave console.

To set up both consoles so that pistons are used to control registrations:

- Select "Pistons" for the "Stop Change – Snd" parameter on the Master console.
- Select "Piston" or "Stops & Pist" for the "Stop Change – Rcv" parameter on the Slave console.

After this setup is accomplished, selecting a memory on the Master console will also select that memory on the Slave console. The contents of each memory can be different.

If there are times you want to use the resources of one instrument alone (i.e., the other is silent), select a registration memory on the console to be heard and prepare the same memory on the other console in such a way that it contains no active stops. That way, even though a memory is selected on both the Master and the Slave console, only the instrument that has active stops activated will be heard.

Note: You can also use "Local" to silence the desired divisions on the Master console.

Seq. Update

MIDI sequencers generate MIDI messages when they start and stop, namely "Start", "Stop" and "Continue".

The 538/i548 uses these sequencer messages to automatically record the registration and expression shoe status at the beginning of a sequence. When a MIDI Start command is received, the organ sends the status of all stops and couplers plus the position of the expression shoes to the sequencer; the initial status of the organ is therefore recorded in the sequence and later recreated during playback.

The organ also sends Program Change, Bank Select and Expression information for all active MIDI couplers when a Start command is received.

The "Seq. Update" ("Sequencer Update") parameter in the "MIDI Settings – General" menu defines how the organ responds to Start, Stop and Continue messages sent from a sequencer. When the value is set to "On", proper communication is ensured. This is the configuration that should be used in the vast majority of applications. When set to "Off", the organ does not respond to Start messages; this configuration is reserved for very specific uses and won't be applicable to most users.

Most hardware sequencers (like the Rodgers MR-200) transmit Start, Stop and Continue values automatically unless you manually disable them. Some software

sequencers may need to have the Start/Stop/Continue transmission enabled from within their MIDI configuration menus.

To turn Sequencer Update on or off:

- (1) Press **[QUICK MENU]**.
- (2) Use the Select knob to select "MIDI Setting".
- (3) Confirm your choice by pressing **[QUICK MENU]**.
- (4) Choose "General" with the Select knob.



- (5) Confirm your choice by pressing **[QUICK MENU]**.
- (6) Choose "Seq. Update" with the Select knob.



- (7) Use the data entry wheel to select the desired setting ("On" or "Off").
- (8) Save your settings if you wish to keep them. See page 54.
- (9) Press and hold the **[EXIT]** piston to return to the main page.

MIDI connections

There are three MIDI jacks on the 538/i548, labeled **MIDI IN/OUT/THRU**. They are located on the connector panel to the right below the keydesk.

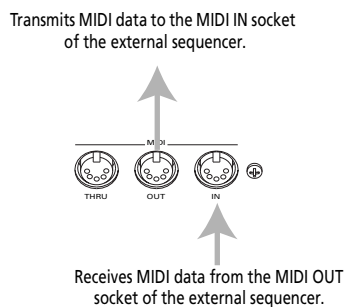

Connect a sequencer (such as the Rodgers MR-200) to the MIDI IN and OUT sockets on the organ. Connect its MIDI OUT socket to the 538/i548's MIDI IN and the MIDI IN port of the MR-200 to the 538/i548's MIDI OUT socket. **The sequencer must not be in Soft Thru mode.**

MIDI Device ID

MIDI Device ID is an identification number used in System Exclusive Stop Control messages. This ID number can be used to allow independent control over multiple organ consoles connected via MIDI or to facilitate storing multiple sets of registration information on a sequencer recording.

Normally, the organ both sends and recognizes an ID number of 17; stop messages with other ID numbers are ignored. When multiple consoles are controlled via MIDI, each can use a different ID number, thereby allowing independent control of each console's registration.

The number can be set to 1, or 17 through 32. Setting the ID to 1 produces Stop Control messages that are compatible with older Rodgers PDI and C-Series organs.

In most cases, the ID will not need to be changed.

- (1) Press **[QUICK MENU]**.
- (2) Use the Select knob to select "MIDI Setting".
- (3) Confirm your choice by pressing **[QUICK MENU]**.
- (4) Choose "General" with the Select knob.



- (5) Confirm your choice by pressing **[QUICK MENU]**.
- (6) Choose "Device ID" with the Select knob.



- (7) Use the data entry wheel to select the desired setting (1, 17~32).
- (8) Save your settings if you wish to keep them. See page 54.
- (9) Press and hold the **[EXIT]** piston to return to the main page.

Saving MIDI settings

Many changes to MIDI settings are temporary and are lost when the organ is turned off. You can, however store many of these new settings as the default, so that the change is retained when the organ is powered off.

Please note that there are a few MIDI settings that cannot be changed or saved.

- (1) Press **[QUICK MENU]**.
- (2) Use the Select knob to select "Memory Setup".



- (3) Confirm your choice by pressing **[QUICK MENU]**. This takes you to a lower level with several options.
- (4) Use the Select knob to select "Parameter Save".



- (5) Confirm your choice by pressing **[QUICK MENU]**. This takes you to a lower level with several options.



- (6) Choose "MIDI Parameters" with the Select knob.
- (7) Confirm your choice by pressing **[QUICK MENU]**.



Note: The 538/i548 has *one* MIDI parameter memory whose contents will be overwritten the next time you save your MIDI settings. That is why you also have the option to save your settings to a USB storage device.

Depending on what you select, the display now looks like this...



Press the **[+]** piston to save your settings internally.

...or like this:



- Use the Select knob to move the cursor (the white square) left or right.
- Select the desired character with the data entry wheel.
- Press the **[+]** piston to save your settings.

The "MIDI Parameters" settings are saved ("Function Completed").

- (8) Press and hold the **[← EXIT]** piston to return to the main page.

Note: While on a "MIDI" page, you can also press and hold the **[SET]** piston while pressing **[0]**. Continue to hold both pistons for a few seconds, until the "Function Completed" message. Then, release both pistons. The changes have been saved as the default.

6. Data management functions

Using the 'Memory Set' function

Saving the general and divisional memories

The 538/i548 allows you to save the settings of the divisional and general memories to a USB storage device, so that you can take your registrations with you. If the location where you perform also has a Rodgers 538/i548 organ, all you need to do is connect your USB storage device to that organ's USB port and use the "Parameters Load – Memory Set" function discussed below. (You can do the same with your "General Parameters" and "MIDI Settings/MIDI General" settings: see pages 42 and 54.)

But let us first have a look at how to store your "Memory Set" registrations.

Note: See p. 42 for how to format your USB storage device if you are planning to use a new one.

- (1) Press **[QUICK MENU]**.
- (2) Use the Select knob to select "Memory Setup".



- (3) Confirm your choice by pressing **[QUICK MENU]**. This takes you to a lower level with several options.
- (4) Use the Select knob to select "Parameter Save".



- (5) Confirm your choice by pressing **[QUICK MENU]**. This takes you to a lower level with several options.
- (6) Choose "Memory Set" with the Select knob.



- (7) Connect your USB storage device to the 538/i548's USB port (below the data entry wheel). If you forget to do this, the following message appears when you execute step (8).



- (8) Confirm your choice by pressing **[QUICK MENU]**.



Now you can name your "Memory Set" file. We recommend using a name that will allow you to quickly locate this set at a later stage. Each USB storage device can indeed hold several "Memory Set" files.

- (9) Use the Select knob to move the cursor (the white square) left or right.
- (10) Select the desired character with the data entry wheel.
- (11) Press the **[+]** piston to save your settings.



- (12) Press and hold the **[EXIT]** piston to return to the main page.

Loading the general and divisional memories

Apart from being able to take your registrations to other locations by saving them to a USB storage device, the previous function also allows you to archive your settings by copying them from the USB storage device to your computer's hard disk.

To restore such a set, i.e. reload it into the 538/i548, proceed as follows. Be aware, however, that **this will overwrite the 538/i548's internal general and divisional memories.**

- (1) Press **[QUICK MENU]**.
- (2) Use the Select knob to select "Memory Setup".



- (3) Confirm your choice by pressing **[QUICK MENU]**. This takes you to a lower level with several options.
- (4) Use the Select knob to select "Parameter Load".



- (5) Confirm your choice by pressing **[QUICK MENU]**. This takes you to a lower level with several options.

- (6) Choose "Memory Set" with the Select knob.



- (7) Connect your USB storage device to the 538/i548's USB port (below the data entry wheel).

If you forget to do this, the following message appears when you execute step (8).



- (8) Confirm your choice by pressing **QUICK MENU**.

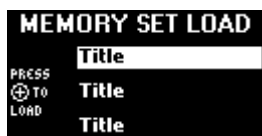

- (9) Use the Select knob to select the "Memory Set" file you want to load.

Be aware that this will overwrite the 538/i548's internal general and divisional memories. You may want to save the internal settings to your USB storage device before proceeding (page 55).

- (10) Press the **+** piston to load the settings.



- (11) Press and hold the **EXIT** piston to return to the main page.

Loading general or MIDI parameter sets

"GeneralParam" and "MIDI Parameters" sets you saved to a USB storage device (see pages 42 and 54) can be loaded into the 538/i548 again to replace the settings currently contained in the organ's internal memory. Again, it would be a good idea to save the settings currently contained in the 538/i548's internal memory to a USB storage device before proceeding.

- (1) Press **QUICK MENU**.
(2) Use the Select knob to select "Memory Setup".



- (3) Confirm your choice by pressing **QUICK MENU**. This takes you to a lower level with several options.

- (4) Use the Select knob to select "Parameter Load".



- (5) Confirm your choice by pressing **QUICK MENU**. This takes you to a lower level with several options.



- (6) Choose "MIDI Parameters" (see above) or "General-Param" with the Select knob.



This choice depends on whether you want to load MIDI or general settings.

- (7) Connect your USB storage device to the 538/i548's USB port (below the data entry wheel).

- (8) Confirm your choice by pressing **QUICK MENU**.



- (9) Use the Select knob to select the file you want to load.

Be aware that this will overwrite the 538/i548's internal settings of the selected section. You may want to save the internal settings to your USB storage device before proceeding.

- (10) Press the **+** piston to load the settings.



- (11) Press and hold the **EXIT** piston to return to the main page.

Restoring the factory-default memory settings

The 538/i548 allows you to reload the factory settings for the following memory areas: the general and divisional memories ("Memory Set"), "Audio Control" settings ("GeneralParam") and MIDI settings ("MIDI Parameters"). As doing so will overwrite the settings you have stored internally, consider saving them to a USB storage device before proceeding. See pages 42, 54 and 55.

- (1) Briefly press **[QUICK MENU]**.
- (2) Use the Select knob to select "Memory Setup".



- (3) Confirm your choice by pressing **[QUICK MENU]**. This takes you to a lower level with several options.
- (4) Use the Select knob to select "Factory Set".



- (5) Confirm your choice by pressing **[QUICK MENU]**. This takes you to a lower level with several options.



- (6) Choose "MIDI Parameters", "Memory Set" or "GeneralParameters" with the Select knob. This choice depends on whether you want to load MIDI or general settings.
- (7) Press the **[+]** piston to load the selected factory settings.



- (8) Press and hold the **[+ EXIT]** piston to return to the main page.

This page intentionally left blank.

This page intentionally left blank.

7. Care and maintenance

As with any fine musical instrument, reasonable care is necessary to protect your investment. Normally no difficulties should be experienced, as only the finest component parts are used by Rodgers. If your instrument should require service, your Rodgers Service Representative is fully equipped and qualified to handle any service problems that may arise.

Your new Rodgers organ is not only a fine musical instrument, but also a fine piece of custom-made furniture finished to hold its attractiveness through generations of use. Each finish coat is thoroughly dried before the next coat is applied. A final catalytic process protective coat makes the Rodgers console impermeable to many harmful substances. The resulting finish is lasting and easy to keep looking beautiful. Following are a few tips on caring for your Rodgers organ.

Console and pedalboard

A frequent dusting with a soft, clean cloth is usually all that is required. Always wipe the surfaces with the grain, using straight, even strokes.

Since extreme cold, heat or exposure to sunlight may injure the finish of any fine piece of furniture, the console should not be placed over a heat register or near a window.

Keyboards and stop tabs

Keyboards and tabs should be cleaned with a soft cloth slightly dampened with water and a mild soap. Avoid dripping water between the keys. **DO NOT USE SOLVENTS** (alcohol, gasoline, carbon tetrachloride, etc.).

8. Miscellaneous

Pipe support

Rodgers organs support pipes that can be controlled via MIDI.

List of shortcuts

Below please find a list of shortcuts that may come in handy whenever you need to make quick changes to a given aspect. The plus sign (“+”) means that you need to press and hold the first piston while pressing the second.

Shortcut	Function
SET + ▶/■	Calls up the “SONG RECORDER - Metronome” page.
SET + 0	Allows you to save general parameter settings.
SET + TREMULANT.I	Calls up the “PIPE MODELING - Tremulant I” page.
SET + TREMULANT.II	Calls up the “PIPE MODELING - Tremulant II” page.
SET + General piston 1~8	Saves all eligible settings to a general registration memory.
SET + Divisional piston 1~5	Saves all eligible settings to a divisional registration memory (for Manual I or II).
SET + BASS coupler	Allows you to set the split point for the BASS coupler range.
SET + MELODY coupler	Allows you to set the split point for the MELODY coupler range.
SET + ORCH PEDAL	Calls up the “ORCHEST SETTING - Pedal” page.
SET + ORCH MAN.I	Calls up the “ORCHEST SETTING - Manual I” page.
SET + ORCH MAN.II	Calls up the “ORCHEST SETTING - Manual II” page.
SET + MIDI PEDAL	Calls up the “MIDI SETTING- Pedal” page.
SET + MIDI MAN.I	Calls up the “MIDI SETTING - Manual I” page.
SET + MIDI MAN.II	Calls up the “MIDI SETTING - Manual II” page.
Press and hold M+	Select the “CONSOLE - Memory Bank - Set” page.

Rodgers MIDI System Exclusive

Rodgers organs use a subset of the Roland standard MIDI System Exclusive format.

All Rodgers SysEx packets use the Roland “Data Set” command, listed under “One Way Transfer Procedure” in the Roland System Exclusive format specification.

The first five bytes of this type of packet are as follows:

Byte	Function
FOH	Begin System Exclusive
41H	Roland/Rodgers SysEx ID
10H	Device ID*
30H	Model ID (30 = Generic organ data) (00 47 = 538/i548 data)
12H	Data Set Command

Note: This byte is usually 10H; however, the organ receives 00H~0FH and can be set to transmit Device ID 00H or transmit and receive any Device ID between 10H and 1FH.

See the last page of these notes for more information.

This header is then followed by the message body. The message body contains a subcommand byte, an optional offset byte and a variable number of data bytes followed by a checksum byte and a MIDI End Exclusive byte (F7). The checksum byte value is such that if all bytes beginning with the subcommand byte and ending with the checksum byte are added, the lower 7 bits of the result will be all zeroes.

The following messages are used by Rodgers as of the introduction of models 538/i548:

1. Stop change

This message is transmitted each time one or more stops, couplers, or auxiliary controls changes state.

The state of each control is represented as a bit in one of the message data bytes.

The assignment of controls to specific bits is standardized for all Rodgers organs by use of the master code assignment list included herein.

Activated controls ("on") are represented by ones in the bit map.

This message is transmitted on the Sequencer and Pipe ports only on organs which have a separate MIDI Instrument port.

It can, however, be received on the Instrument port as well.

Subcommand byte: 01H

Offset byte: 00H~22H This byte indicates the offset of the first data byte from the beginning of the bitmap. Normally, this will be zero, and the entire map (35 bytes) will be transmitted. It is possible, though, to send only part of the map beginning with the byte indicated by this value.

Data bytes: dd, dd,... The data bytes represent the new state of the bit map beginning at the offset specified above. Any number of data bytes up to the full length of the bit map may be sent, although the entire map is usually transmitted. Refer to the included chart for stop map assignments.

2. Memory dump

This message is transmitted when you transmit ("dump") a Combination memory to a sequencer. The body of the message contains the data of all Combination memories; several such messages are usually necessary to transmit the complete contents of all the memories.

Subcommand byte: 03H

Offset byte: mm This byte contains the zero-indexed number of the combination memory being dumped.

Data Bytes: dd, dd, ... The data for the memory is converted from one byte with 8 significant bits to two bytes with 4 significant bits each. The high order bits are contained in the low order nibble of the first byte. The low order bits are contained in the low order nibble of the second byte. The contents of the piston data structure is proprietary and not disclosed.

NRPN (CC99 & CC98) addresses to use for selecting Orchestral Voices via MIDI:

Status	2nd byte	3rd byte
BnH	63H	mmH
BnH	62H	IIH
	n=	MIDI channel number: 0H~FH (Ch. 1~16)
	mm=	upper byte (MSB) of the parameter number specified by NRPN 50H (80 d) Program Change 51H (81 d) Variation
	II=	lower byte (LSB) of the parameter number specified by NRPN

Example:

BB 99	80	
BB 98	00	
BB 06	xx	= (Program Change) PC
BB100	127	
BB101	127	
BB 99	81	
BB 98	00	
BB 06	xx	= (Variations) VC
BB100	127	
BB101	127	

MIDI Implementation Chart

Rodgers

Model: 538/i548

Date: May 2007

Version: 1.00

Function...		Transmitted	Recognized	Remarks
Basic Channel	Default Changed	1~3, 12~14 *1 1, 4~11 (Man I) *1	12~14	*1 12= MAN.I, 13= MAN.II, 14= PEDAL
Mode	Default Message Altered	Mode 3 X *****	Mode 3 X	
Note Number	True Voice	6~126 *****	35~96 *****	
Velocity	Note ON Note OFF	O only ORCH Voice O only ORCH voice	O only ORCH Voice O only ORCH voice	
After Touch	Key's Ch's	X X	X X	
Pitch Bend		X	X	
Control Change		0,32 O 6 O 7 O 10 O 11 O 64 O 66 O 67 O 91 O 93 O 98, 99 O 100, 101 O	X O O X O O O O X (Reverb) X (Chorus) O O	Bank Select Data Entry Volume Panpot Expression Hold 1 Sostenuto Soft Effect 1 Depth Effect 3 Depth NRPN LSB, MSB RPN LSB, MSB
Program Change	True #	O *****	1~8 21~25	Progr. Number 1~128
System Exclusive		O *2	O *2	
System Common	Song Position Pointer Song Sel Tune	X X O	X X O	*4
System Real Time	Clock Commands	X X	X O	*3
Aux Messages	All Sounds Off Reset All Controllers Local On/Off All Notes Off Active Sense Reset	X X X X O X	X X X X O X	
Notes		*1 O X is selectable. *2 SysEx used for stop changes, Combination memory dump. *3 Received Start sends current stop and Expression status Received Stop restores expression to shoe positions Received Continue sets Expression to values at last stop. *4 O X is selectable (on or off)		

Mode 1: OMNI ON, POLY
 Mode 3: OMNI OFF, POLY

Mode 2: OMNI ON, MONO
 Mode 4: OMNI OFF, MONO

O: Yes
 X: No

This page intentionally left blank.

Information

When you need repair service, call your nearest Roland Service Center or authorized Roland distributor in your country as shown below.

AFRICA**EGYPT**

Al Fanny Trading Office
9, EBN Hagar Al Askalany
Street,
ARD El Golf, Heliopolis,
Cairo 11341, EGYPT
TEL: (022)-418-5531

REUNION

Maison FO - YAM Marcel
25 Rue Jules Hermann,
Chaudron - BP79 97 491
Ste Clotilde Cedex,
REUNION ISLAND
TEL: (0262) 218-429

SOUTH AFRICA

T.O.M.S. Sound & Music
(Pty)Ltd.
2 ASTRON ROAD DENVER
JOHANNESBURG ZA 2195,
SOUTH AFRICA
TEL: (011)417 3400

Paul Bothner(Pty)Ltd.
Royal Cape Park, Unit 24
Londonderry Road, Ottery 7800
Cape Town, SOUTH AFRICA
TEL: (021) 799 4900

ASIA**CHINA**

Roland Shanghai Electronics
Co.,Ltd.
5F. No.1500 Pingliang Road
Shanghai 200090, CHINA
TEL: (021) 5580-0800

Roland Shanghai Electronics
Co.,Ltd.
(BEIJING OFFICE)
10F. No.18 3 Section Anhuaxili
Chaoyang District Beijing
100011 CHINA
TEL: (010) 6426-5050

HONG KONG

Tom Lee Music Co., Ltd.
Service Division
22-32 Pun Shan Street, Tsuen
Wan, New Territories,
HONG KONG
TEL: 2415 0911

Parsons Music Ltd.
8th Floor, Railway Plaza, 39
Chatham Road South, T.S.T.,
Kowloon, HONG KONG
TEL: 2333 1863

INDIA

Rivera Digitec (India) Pvt. Ltd.
411, Nirman Kendra
Mahalaxmi Flats Compound
Off. Dr. Edwin Moses Road,
Mumbai-400011, INDIA
TEL: (022) 2493 9051

INDONESIA

PT Citra IntiRama
Jl. Cideng Timur No. 15J-150
Jakarta Pusat
INDONESIA
TEL: (021) 6324170

KOREA

Cosmos Corporation
1461-9, Seocho-Dong,
Seocho Ku, Seoul, KOREA
TEL: (02) 3486-8855

MALAYSIA

Roland Asia Pacific Sdn. Bhd.
45-1, Block C2, Jalan PJU 1/39,
Dataran Prima, 47301 Petaling
Jaya, Selangor, MALAYSIA
TEL: (03) 7805-3263

VIET NAM

Suoi Nhac Company, Ltd
370 Cach Mang Thang Tam St.
Dist.3, Ho Chi Minh City,
VIET NAM
TEL: 9316540

PHILIPPINES

G.A. Yupangco & Co. Inc.
339 Gil J. Puyat Avenue
Makati, Metro Manila 1200,
PHILIPPINES
TEL: (02) 899 9801

SINGAPORE

SWEE LEE MUSIC
COMPANY PTE. LTD.
150 Sims Drive,
SINGAPORE 387381
TEL: 6846-3676

TAIWAN

ROLAND TAIWAN
ENTERPRISE CO., LTD.
Room 5, 9fl. No. 112 Chung
Shan N.Road Sec.2, Taipei,
TAIWAN, R.O.C.
TEL: (02) 2561 3339

THAILAND

Theera Music Co., Ltd.
100-108 Soi Verng
Nakornkasem, New
Road,Sumpantawongse,
Bangkok 10100 THAILAND
TEL: (02) 224-8821

**AUSTRALIA/
NEW ZEALAND****AUSTRALIA/
NEW ZEALAND**

Roland Corporation
Australia Pty.,Ltd.
38 Campbell Avenue
Dee Why West. NSW 2099
AUSTRALIA

For Australia
Tel: (02) 9982 8266
For New Zealand
Tel: (09) 3098 715

**CENTRAL/LATIN
AMERICA****ARGENTINA**

Instrumentos Musicales S.A.
Av.Santa Fe 2055
(1123) Buenos Aires
ARGENTINA
TEL: (011) 4508-2700

BARBADOS

A&B Music Supplies LTD
12 Webster Industrial Park
Wildsey, St.Michael, Barbados
TEL: (246)430-1100

BRAZIL

Roland Brasil Ltda.
Rua San Jose, 780 Sala B
Parque Industrial San Jose
Cofia - Sao Paulo - SP, BRAZIL
TEL: (011) 4615 5666

CHILE

Comercial Fancy II S.A.
Rut.: 96.919.420-1
Nataníel Cox #739, 4th Floor
Santiago - Centro, CHILE
TEL: (02) 688-9540

COLOMBIA

Centro Musical Ltda.
Cra 43 B No 25 A 41 Bododega 9
Medellin, Colombia
TEL: (574)3812529

COSTA RICA

JUAN BANSBACH Instrumentos
Musicales
Ave.1. Calle 11, Apartado
10237,
San Jose, COSTA RICA
TEL: 258-0211

CURACAO

Zeelandia Music Center Inc.
Orionweg 30
Curacao, Netherland Antilles
TEL:(305)5926866

DOMINICAN REPUBLIC

Instrumentos Fernando Giraldez
Calle Proyecto Central No.3
Ens.La Esperilla
Santo Domingo,
Dominican Republic
TEL:(809) 683 0305

ECUADOR

Mas Musika
Rumichaca 822 y Zaruma
Guayaquil - Ecuador
TEL:(593-4)2302364

EL SALVADOR

OMNI MUSIC
75 Avenida Norte y Final
Alameda Juan Pablo II,
Edificio No.4010 San Salvador,
EL SALVADOR
TEL: 262-0788

GUATEMALA

Casa Instrumental
Calzada Roosevelt 34-01,zona 11
Ciudad de Guatemala
Guatemala
TEL:(502) 599-2888

HONDURAS

Almacen Pajaro Azul S.A. de C.V.
BO.Paz Barahona
3 Ave.11 Calle S.O
San Pedro Sula, Honduras
TEL: (504) 553-2029

MARTINIQUE

Musique & Son
Z.I.Les Mangle
97232 Le Lamantin
Martinique F.W.I.
TEL: 596 596 426860

Gigamusic SARI

10 Rte De La Folie
97200 Fort De France
Martinique F.W.I.
TEL: 596 596 715222

MEXICO

Casa Veerkamp, s.a. de c.v.
Av. Toluca No. 323, Col. Olivar
de los Padres 01780 Mexico
D.F. MEXICO
TEL: (55) 5668-6699

NICARAGUA

Bansbach Instrumentos
Musicales Nicaragua
Altamira D'Este Calle Principal
de la Farmacia 5ta Avenida
1 Cuadra al Lago.#503
Managua, Nicaragua
TEL: (505)277-2557

PANAMA

SUPRO MUNDIAL, S.A.
Boulevard Andrews, Albrook,
Panama City, REP. DE
PANAMA
TEL: 315-0101

PARAGUAY

Distribuidora De
Instrumentos Musicales
J.E. Olear y ESQ. Manduvira
Asuncion PARAGUAY
TEL: (595) 21 492147

PERU

Audionet
Distribuciones Musicales SAC
Juan Fanning 530
Miraflores
Lima - Peru
TEL: (511) 4461388

TRINIDAD

AMR Ltd
Ground Floor
Maritime Plaza
Barataria Trinidad W.I.
TEL: (868) 638 6385

URUGUAY

Todo Musica S.A.
Francisco Acuna de Figueroa
1771
C.P.: 11.800
Montevideo, URUGUAY
TEL: (02) 924-2335

VENEZUELA

Instrumentos Musicales
Allegro,C.A.
Av.las industrias edf.Guitar
import
#7 zona Industrial de Turumo
Caracas, Venezuela
TEL: (212) 244-1122

EUROPE**AUSTRIA**

Roland Elektronische
Musikinstrumente HmbH.
Austrian Office
Eduard-Bodem-Gasse 8,
A-6020 Innsbruck, AUSTRIA
TEL: (0512) 26 44 260

**BELGIUM/FRANCE/
HOLLAND/
LUXEMBOURG**

Roland Central Europe N.V.
Houtstraat 3, B-2260, Oevel
(Westerlo) BELGIUM
TEL: (014) 575811

CROATIA

ART-CENTAR
Degenova 3,
HR - 10000 Zagreb
TEL: (1) 466 8493

CZECH REP.

CZECH REPUBLIC
DISTRIBUTOR s.r.o.
Votárova 247/16
CZ - 180 00 PRAHA 8,
CZECH REP.
TEL: (2) 830 20270

DENMARK

Roland Scandinavia A/S
Nordhavnsvej 7, Postbox 880,
DK-2100 Copenhagen
DENMARK
TEL: 3916 6200

FINLAND

Roland Scandinavia As, Finland
Finland
Elannontie 5
FIN-01510 Vantaa, FINLAND
TEL: (09) 68 24 020

GERMANY

Roland Elektronische
Musikinstrumente HmbH.
Oststrasse 96, 22844
Norderstedt, GERMANY
TEL: (040) 52 60090

GREECE/CYPRUS

STOLLAS S.A.
Music Sound Light
155, New National Road
Patras 26442, GREECE
TEL: 2610 435400

HUNGARY

Roland East Europe Ltd.
Warehouse Area "DEPO" Pf.83
H-2046 Torokbalint,
HUNGARY
TEL: (23) 511011

IRELAND

Roland Ireland
G2 Calmount Park, Calmount
Avenue, Dublin 12
Republic of IRELAND
TEL: (01) 4294444

ITALY

Roland Italy S. p. A.
Viale delle Industrie 8,
20020 Arese, Milano, ITALY
TEL: (02) 937-78300

NORWAY

Roland Scandinavia Avd.
Kontor Norge
Lilleakerveien 2 Postboks 95
Lilleaker N-0216 Oslo
NORWAY
TEL: 2273 0074

POLAND

ROLAND POLSKA SP. Z O.O.
UL. Gibraltarska 4.
PL-03 664 Warszawa
POLAND
TEL: (022) 679 4419

PORTUGAL

Roland Iberia, S.L.
Portugal Office
Cais das Pedras, 8/9-1 Dto
4050-465, Porto, PORTUGAL
TEL: 22 608 00 60

ROMANIA

FBS LINES
Piata Libertatii 1,
535500 Gheorgheni,
ROMANIA
TEL: (266) 364 609

RUSSIA

MuTek
Dorozhnaya ul.3,korp.6
117 545 Moscow, RUSSIA
TEL: (095) 981-4967

SLOVAKIA

DAN Acoustic s.r.o.
Povazská 18,
SK - 940 01 Nové Zámky
TEL: (035) 6424 330

SPAIN

Roland Iberia, S.L.
Paseo García Faria, 33-35
08005 Barcelona SPAIN
TEL: 93 493 91 00

SWEDEN

Roland Scandinavia A/S
SWEDISH SALES OFFICE
Danvik Center 28, 2 tr.
S-131 30 Nacka SWEDEN
TEL: (08) 702 00 20

SWITZERLAND

Roland (Switzerland) AG
Landstrasse 5, Postfach,
CH-4452 Itingen,
SWITZERLAND
TEL: (061) 927-8383

UKRAINE

EURHYTHMICS Ltd.
P.O.Box: 37-a,
Nedecy Str.30
UA - 89600 Mukachevo,
UKRAINE
TEL: (03131) 414-40

UNITED KINGDOM

Roland (U.K.) Ltd.
Atlantic Close, Swansea
Enterprise Park, SWANSEA
SA7 9FJ,
UNITED KINGDOM
TEL: (01792) 702701

MIDDLE EAST**BAHRAIN**

Moon Stores
No.1231&1249 Rumaytha
Building Road 3931, Manama
339 BAHRAIN
TEL: 17 813 942

IRAN

MOCO INC.
No.41 Nike St., Dr.Shariyati Ave.,
Roberoye Cerahe Mirdamad
Tehran, IRAN
TEL: (021)-2285-4169

ISRAEL

Halilit P. Greenspoon & Sons
Ltd.
8 Retzif Ha'alia Hashnia St.
Tel-Aviv-Yafo ISRAEL
TEL: (03) 6823666

JORDAN

MUSIC HOUSE CO. LTD.
FREDDY FOR MUSIC
P. O. Box 922846
Amman 11192 JORDAN
TEL: (06) 5692696

KUWAIT

EASA HUSAIN AL-YOUSIFI
& SONS CO.
Al-Yousifi Service Center
P.O.Box 126 (Safat) 13002
KUWAIT
TEL: 00 965 802929

LEBANON

Chahine S.A.L.
George Zeidan St., Chahine
Bldg., Achrafieh, P.O.Box: 16-
5857
Beirut, LEBANON
TEL: (01) 20-1441

OMAN

TALENTZ CENTRE L.L.C.
Malatan House No.1
Al Noor Street, Ruwi
SULTANATE OF OMAN
TEL: 2478 3443

QATAR

Al Emadi Co. (Badie Studio &
Stores)
P.O. Box 62, Doha, QATAR
TEL: 4423-554

SAUDI ARABIA

aDawlah Universal
Electronics APL
Behind Pizza Inn
Prince Turkey Street
aDawlah Building,
PO BOX 2154,
Alkhubar 31952
SAUDI ARABIA
TEL: (03) 8643601

SYRIA

Technical Light & Sound
Center
Rawda, Abdul Qader Jazairi St.
Bldg. No. 21, P.O.Box 13520,
Damascus, SYRIA
TEL: (011) 223-5384

TURKEY

ZUHAL DIS TICARET A.S.
Galip Dede Cad. No.37
Beşiktaş - Istanbul / TURKEY
TEL: (0212) 249 85 10

U.A.E.

Zak Electronics & Musical
Instruments Co. L.L.C.
Zabeel Road, Al Sherooq Bldg.,
No. 14, Ground Floor, Dubai,
U.A.E.
TEL: (04) 3360715

NORTH AMERICA**CANADA**

Roland Canada Ltd.
Roland Canada Ltd.
(Head Office)
5480 Parkwood Way
Richmond B. C., V6V 2M4
CANADA
TEL: (604) 270 6626

Roland Canada Ltd.

(Toronto Office)
170 Admiral Boulevard
Mississauga On L5T 2N6
CANADA
TEL: (905) 362 9707

U. S. A.

Roland Corporation U.S.
5100 S. Eastern Avenue
Los Angeles, CA 90040-2938,
U. S. A.
TEL: (323) 890 3700

This page intentionally left blank.



This product complies with the requirements of European Directives EMC 89/336/EEC and LVD 73/23/EEC.

For EU Countries

For the USA

FEDERAL COMMUNICATIONS COMMISSION RADIO FREQUENCY INTERFERENCE STATEMENT

This equipment has been tested and found to comply with the limits for a Class B digital device, pursuant to Part 15 of the FCC Rules. These limits are designed to provide reasonable protection against harmful interference in a residential installation. This equipment generates, uses, and can radiate radio frequency energy and, if not installed and used in accordance with the instructions, may cause harmful interference to radio communications. However, there is no guarantee that interference will not occur in a particular installation. If this equipment does cause harmful interference to radio or television reception, which can be determined by turning the equipment off and on, the user is encouraged to try to correct the interference by one or more of the following measures:

- Reorient or relocate the receiving antenna.
- Increase the separation between the equipment and receiver.
- Connect the equipment into an outlet on a circuit different from that to which the receiver is connected.
- Consult the dealer or an experienced radio/TV technician for help.

This device complies with Part 15 of the FCC Rules. Operation is subject to the following two conditions:

- (1) This device may not cause harmful interference, and
- (2) This device must accept any interference received, including interference that may cause undesired operation.

Unauthorized changes or modification to this system can void the users authority to operate this equipment.
This equipment requires shielded interface cables in order to meet FCC class B Limit.

For Canada

NOTICE

This Class B digital apparatus meets all requirements of the Canadian Interference-Causing Equipment Regulations.

AVIS

Cet appareil numérique de la classe B respecte toutes les exigences du Règlement sur le matériel brouilleur du Canada.

For EU Countries



UK This symbol indicates that in EU countries, this product must be collected separately from household waste, as defined in each region. Products bearing this symbol must not be discarded together with household waste.

DE Dieses Symbol bedeutet, dass dieses Produkt in EU-Ländern getrennt vom Hausmüll gesammelt werden muss gemäß den regionalen Bestimmungen. Mit diesem Symbol gekennzeichnete Produkte dürfen nicht zusammen mit dem Hausmüll entsorgt werden.

FR Ce symbole indique que dans les pays de l'Union européenne, ce produit doit être collecté séparément des ordures ménagères selon les directives en vigueur dans chacun de ces pays. Les produits portant ce symbole ne doivent pas être mis au rebut avec les ordures ménagères.

IT Questo simbolo indica che nei paesi della Comunità europea questo prodotto deve essere smaltito separatamente dai normali rifiuti domestici, secondo la legislazione in vigore in ciascun paese. I prodotti che riportano questo simbolo non devono essere smaltiti insieme ai rifiuti domestici. Ai sensi dell'art. 13 del D.Lgs. 25 luglio 2005 n. 151.

ES Este símbolo indica que en los países de la Unión Europea este producto debe recogerse aparte de los residuos domésticos, tal como está regulado en cada zona. Los productos con este símbolo no se deben depositar con los residuos domésticos.

PT Este símbolo indica que nos países da UE, a recolha deste produto deverá ser feita separadamente do lixo doméstico, de acordo com os regulamentos de cada região. Os produtos que apresentem este símbolo não deverão ser eliminados juntamente com o lixo doméstico.

NL Dit symbool geeft aan dat in landen van de EU dit product gescheiden van huishoudelijk afval moet worden aangeboden, zoals bepaald per gemeente of regio. Producten die van dit symbool zijn voorzien, mogen niet samen met huishoudelijk afval worden verwijderd.

DK Dette symbol angiver, at i EU-lande skal dette produkt opsamles adskilt fra husholdningsaffald, som defineret i hver enkelt region. Produkter med dette symbol må ikke smides ud sammen med husholdningsaffald.

NO Dette symbolet indikerer at produktet må behandles som spesialavfall i EU-land, iht. til retningslinjer for den enkelte regionen, og ikke kastes sammen med vanlig husholdningsavfall. Produkter som er merket med dette symbolet, må ikke kastes sammen med vanlig husholdningsavfall.

SE Symbolen anger att i EU-länder måste den här produkten kasseras separat från hushållsavfall, i enlighet med varje regions bestämmelser. Produkter med den här symbolen får inte kasseras tillsammans med hushållsavfall.

FI Tämä merkintä ilmaisee, että tuote on EU-maissa kerättävä erillään kotitalousjätteistä kunkin alueen voimassa olevien määräysten mukaisesti. Tällä merkinnällä varustettuja tuotteita ei saa hävittää kotitalousjätteiden mukana.

HU Ez a szimbólum azt jelenti, hogy az Európai Unióban ezt a terméket a háztartási hulladéktól elkülönítve, az adott régióban érvényes szabályozás szerint kell gyűjteni. Az ezzel a szimbólummal ellátott termékeket nem szabad a háztartási hulladék közé dobni.

PL Symbol oznacza, że zgodnie z regulacjami w odpowiednim regionie, w krajach UE produktu nie należy wyrzucać z odpadami domowymi. Produktów opatrzonych tym symbolem nie można utylizować razem z odpadami domowymi.

CZ Tento symbol udává, že v zemích EU musí být tento výrobek sbírán odděleně od domácího odpadu, jak je určeno pro každý region. Výrobky nesoucí tento symbol se nesmí vyhadzovat spolu s domácím odpadem.

SK Tento symbol vyjadruje, že v krajinách EÚ sa musí zber tohto produktu vykonávať oddelene od domového odpadu, podľa nariadení platných v konkrétnej krajine. Produkty s týmto symbolom sa nesmú vyhadzovať spolu s domovým odpadom.

EE See sümbol näitab, et EL-i maades tuleb see toode olemprügist eraldi koguda, nii nagu on igas piirkonnas määratletud. Selle sümboliga märgitud tooteid ei tohi ära visata koos olmeprügiga.

LT Šis simbolis rodo, kad ES šalyse šis produktas turi būti surenkamas atskirai nuo buitinių atliekų, kaip nustatyta kiekvienoje regione. Šiuo simboliu paženklinyti produktai neturi būti išmetami kartu su buitiniomis atliekomis.

LV Šis simbols norāda, ka ES valstīs šo produktu jāievāc atsevišķi no mājsaimniecības atkritumiem, kā noteikts katrā reģionā. Produkts ar šo simbolu nedrīkst izmest kopā ar mājsaimniecības atkritumiem.

SI Ta simbol označuje, da je treba proizvod v državah EU zbirati ločeno od gospodinskih odpadkov, tako kot je določeno v vsaki regiji. Proizvoda s tem znakom ni dovoljeno odlagati skupaj z gospodinskimi odpadki.

GR Бхфх фп уэмвплл дзлоней ыфй уфйт чюсет фзт ЕЕ, фп рспън бхфх рсЭрей нб ухллЭгефбй оечшщйуфь брь фб пикйбкъ брпсЯммбфб, уэмщнб ме фз нпмшеуЯб фзт кыне респчЮг. Фб рспънфб рпх иЭсплн бхфх фп уэмвплл ден рсЭрей нб брпсЯрфпнфбй мбжЯ ме фб пикйбкъ брпсЯммбфб.

This page intentionally left blank.

For China**有关产品中所含有害物质的说明**

本资料就本公司产品中所含的特定有害物质及其安全性予以说明。

本资料适用于 2007 年 3 月 1 日以后本公司所制造的产品。

环保使用期限

此标志适用于在中国国内销售的电子信息产品，表示环保使用期限的年数。所谓环保使用期限是指在自制造日起的规定期限内，产品中所含的有害物质不致引起环境污染，不会对人身、财产造成严重的不良影响。环保使用期限仅在遵照产品使用说明书，正确使用产品的条件下才有效。不当的使用，将会导致有害物质泄漏的危险。

产品中有毒有害物质或元素的名称及含量

部件名称	有毒有害物质或元素					
	铅(Pb)	汞(Hg)	镉(Cd)	六价铬(Cr(VI))	多溴联苯(PBB)	多溴二苯醚(PBDE)
外壳(壳体)	×	○	○	○	○	○
电子部件(印刷电路板等)	×	○	×	○	○	○
附件(电源线、交流适配器等)	×	○	○	○	○	○

○：表示该有毒有害物质在该部件所有均质材料中的含量均在 SJ/T11363-2006 标准规定的限量要求以下。
 ×：表示该有毒有害物质至少在该部件的某一均质材料中的含量超出 SJ/T11363-2006 标准规定的限量要求。
 因根据现有的技术水平，还没有什么物质能够代替它。

